



Ventilating Filters – Vandalism Proof

LE.0716 • LE.0817

LE.0827 • LE.0818

LE.0819

- With filling filter
- 6 hole flange
- Nominal flow rate up to 850 l/min

Description

Application

Filling / ventilation of tanks for hydraulic and lubrication systems as well as gearboxes.

General

The oil levels in the tanks of hydraulic systems are subject to continuous variation due to temperature changes and the operation of cylinders and pressure vessels.

In order to prevent over pressure in the tanks, an exchange of air with the external atmosphere is necessary. By the use of a ventilating filter, the outside air that is drawn in is filtered and the ingress of dust is therefor prevented.

A combined filling filter prevents coarse impurities from entering during filling or re-filling due to maintenance or repair reasons.

Special features

The profiled metal flange with elastomer sealing and the mounting with 6 screws ensure that the filling / ventilating filters seal reliable even on non-planar tank surfaces. Filler screens made of sturdy expanded metal offer 100% safety during filling of the tank – which excludes any damage being caused for example by the filler neck. The ventilating filter is fixed by a chain at the filling filter to prevent it from being lost (exception: LE.0716). The ventilation openings of the ventilating filters are designed that dust on the surface of the tank is not drawn in, and that the ingress of spray and rainwater is largely prevented.

The patented vandalism proof ventilating filters can only be removed with the special tool supplied. This makes the misuse of the ventilating filter or the ingress of dirt via the filling / ventilation opening considerably more difficult.

Design

Filling filter: cylinder screen - flow direction from centre to outside.

Ventilating filter: Flow direction bi-directional (air IN / OUT). The star-shaped pleating of the filter material results in:

- large filter surfaces
- low pressure drop
- high dirt-holding capacities
- long service life

Ordering options / versions

Integrated oil-level dipstick

A dipstick can be integrated in the ventilating filter for checking the oil level. Therefor, a separate dipstick or an additional opening in the tank is not required.

Double check valve in the ventilating filter:

By the use of double check valves, the exchange of air between the tank and the environment is considerably reduced, whereby the ingress of dust is minimized and the lifetime of the air filter element is increased. With the double check valve, an over-pressure is created in the tank in order to improve the suction conditions for the pumps. A further advantage is the reduction of spray water ingress and the loss of oil through the ventilating filter.

Vandalism proof version "Standard" (LE.0818):

Ventilating filters in the patented vandalism proof version can only be removed with the special spanner supplied (A/F 47).

Vandalism proof version "Easy Lock" (L1.0819):

Ventilating filters in the patented "Easy Lock" version can only be removed with the special pin supplied.

This makes the misuse of the ventilating filter or the ingress of dirt via the filling / ventilation opening considerably more difficult.

Maintenance

Ventilating filters should be changed at least every 1000 operating hours, or at minimum once a year.

Characteristics

Nominal flow rate

Filling filter: up to 140 l/min.

Ventilating filter: up to 850 l/min (see Selection Chart, column 2)

The nominal flow rates indicated by ARGO-HYTOS are based on the following criteria:

- Ventilating filters without double check valve:
 $\Delta p < 0,03$ bar for air IN
- Ventilating filters with double check valve:
 $\Delta p < 0,1$ bar for air IN

Connection

Filling filter: 6 hole flange, hole pattern according to DIN 24557/T2

Ventilating filter: outer thread M42 x 2 (the thread dimensions do not exactly conform to the ISO standard thread / functioning with the ISO standard thread is guaranteed)

Mounting / sealing

Version without double check valve:

6 self-tapping screws ISO 1479-ST4,8x16-C with washers

Version with double check valve:

6 philips head screws ISO 7045 M5x16-4.8-Z with O-rings

Sealing of flange with elastomer gasket

(screws and gaskets included in basic equipment)

Filter fineness

Filling filter: 800 μ m

Ventilating filter: 2 μ m, tested in a single pass test with ISO MTD

Hydraulic fluids

Mineral oil and biodegradable fluids (HEES u. HETG, see info sheet 00.20)

Temperature range hydraulic fluid

- 30 °C ... + 100 °C (temporary - 40 °C ... + 120 °C)

Temperature range environment

- 30 °C ... + 100 °C

Materials

Cap: Polyamide, GF reinforced

Base: Polyamide, GF reinforced

Filler screen: Steel, galvanized

Spanner: Steel, galvanized

Gaskets: NBR (Viton on request)

Filter media: Composite, multi-layer

Mounting position

No limitation , position on the tank see section Layout

Diagrams

Δp -curves for complete filters in Selection Chart, column 2

D1 Pressure drop as a function of the **flow volume**
Air IN/OUT

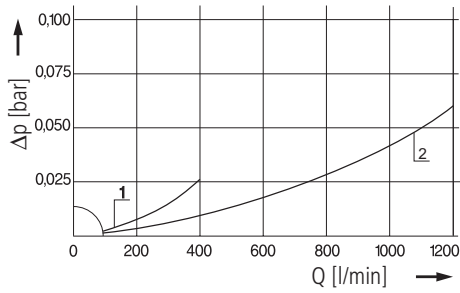

D2 Pressure drop as a function of the **flow volume**
Air IN

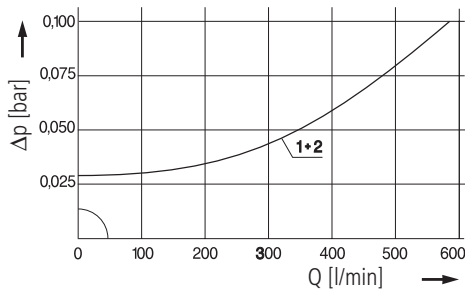

Pressure drop as a function of the **flow volume**
Air OUT

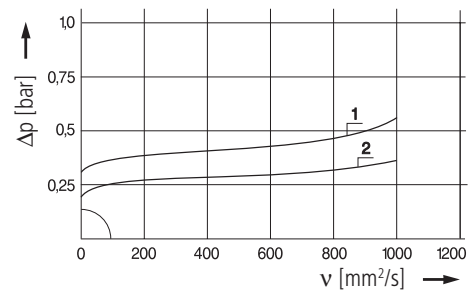

Filter fineness curves in Selection Chart, column 5

Dx Filtration ratio β as a function of particle size x tested in a single pass test with ISO MTD

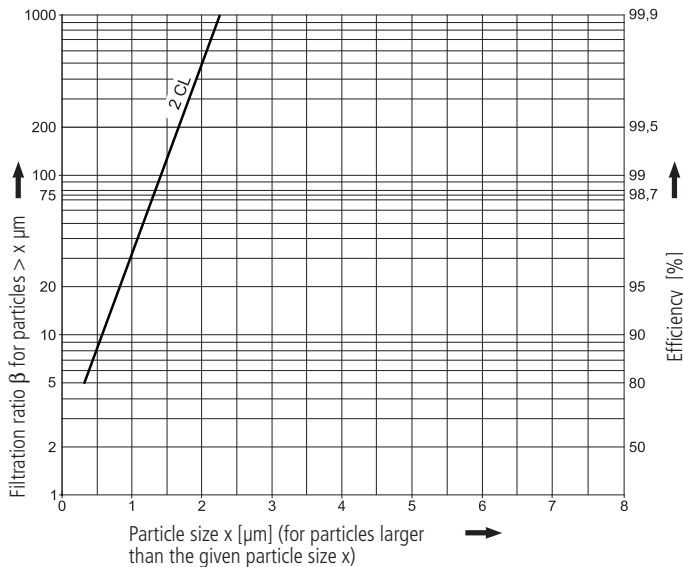

The abbreviations represent the following β -values resp. finenesses:

2 CL = 2 μm Composite
99,5 % efficiency for particles of size 2 μm
tested in a single pass test with ISO MTD

For special applications, finenesses differing from these curves are also available by using special composed filter media.

Dimensions

LE.0716

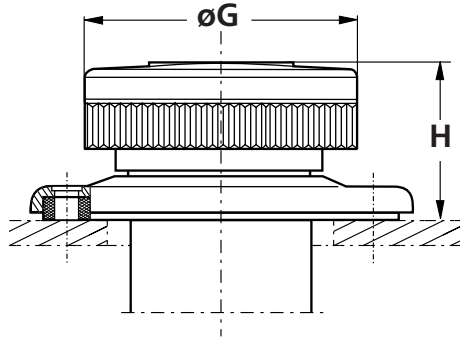

Hole pattern for tank
(core hole $\varnothing D$ for steel material as per table)

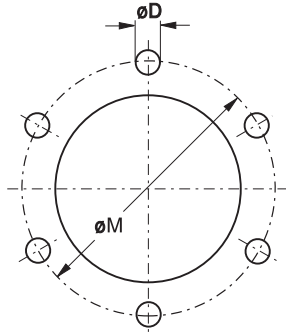

LE.0817 · LE.0827 · LE.0818 · LE.0819

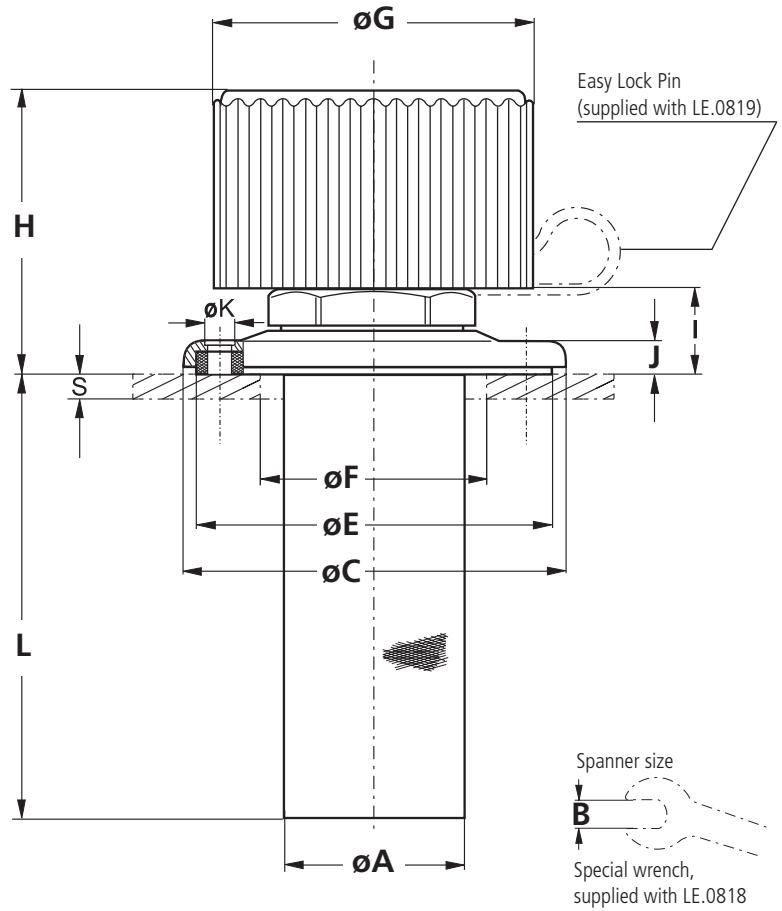

Measurements

Type	A	B	C	E	F	G	H	I	J	K	L	M
LE.0716	46	-	89,5	84,5	58	66	36	15	6	$5,6 \pm 0,3$	111	73
LE.0817	46	47	89,5	84,5	58	80	61	20	6	$5,6 \pm 0,3$	111	73
LE.0827	46	47	89,5	84,5	58	80	61	20	6	$5,6 \pm 0,3$	200	73
LE.0818	46	47	89,5	84,5	58	80	61	20	6	$5,6 \pm 0,3$	111	73
LE.0819	46	47	89,5	84,5	58	80	61	20	6	$5,6 \pm 0,3$	111	73

Plate thickness S over/up to	hole D^*
1,00 / 1,75	3,9
1,75 / 3,00	4,1
3,00 / 4,75	4,4
4,75	M5

* Core hole $\varnothing D$ for self-tapping screws according to DIN 7975 for versions without double check valve. For versions with double check valve always use M5.
Fastening screws included in basic equipment.

Symbols

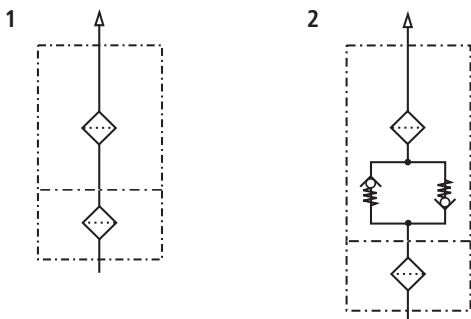

Layout

Sizes

The determining factor for selecting the size is the maximum over / under pressure allowed in the tank.

For versions without double check valves, the initial pressure drop with a clean air filter should not exceed 0,03 bar.

For versions with double check valves, the initial pressure drop for air IN with a clean air filter should not exceed 0,1 bar.

Filter fineness

In the ideal case, the fineness of the ventilating filter matches the fineness of the system filter (see also CETOP RP 98 H).

By the use of filter fineness 2 CL the ingress of dust into the tank is effectively reduced.

Mounting

The ventilating filter should be mounted in a low-dust area of the machine and not in depressions in which water can collect.

For mobile use, the ventilating filter is to be mounted on the tank such that neither splashing oil from the inside nor spray water from the outside can reach the area of the ventilation opening.

Double check valves

By the use of double check valves, the exchange of air between the tank and the environment can be considerably reduced, whereby the ingress of dust is minimized and the lifetime of the air filter element is increased.

With the double check valve, a predefined level of pressure can be created in the tank in order to improve the suction conditions for the pumps.

The valve opening pressure required for the ventilating filter can be approximately determined with the ideal gas equation depending on the following system characteristics:

- differential volume,
- volume of oil in the system,
- volume of air in the tank and the
- operating temperatures.

Quality Assurance

Quality management according to DIN EN ISO 9001

To ensure constant quality in production and operation, ARGO-HYTOS filter elements undergo strict controls and tests according to the following DIN and ISO standards:

DIN ISO 2941	Verification of collapse/burst resistance
DIN ISO 2943	Verification of material compatibility with fluids
DIN ISO 3724	Verification of flow fatigue characteristics

ISO 2942 ISO 3968 ISO 16889

Verification of fabrication integrity (Bubble Point Test)
Evaluation of pressure drop versus flow characteristics
Multi-Pass-Test (evaluation of filter fineness and dirt-holding capacity)

Various quality controls during the production process guarantee the leakfree function and solidity of our filters.

Our engineers will be glad to advice you in questions concerning filter application, selection as well as the cleanliness class of the filtered medium attainable under practical operating conditions.

Illustrations may sometimes differ from the original. ARGO-HYTOS is not responsible for any unintentional mistake in this specification sheet.



We produce fluid power solutions

ARGO-HYTOS GMBH · Industriestraße 9 · D-76703 Kraichtal

Tel: +49 7250 76-0 · Fax: +49 7250 76-199 · info.de@argo-hytos.com · www.argo-hytos.com