



# Vetter: Aircraft Recovery

LIFTING OUT OF LIMITS



Edition 01/2007

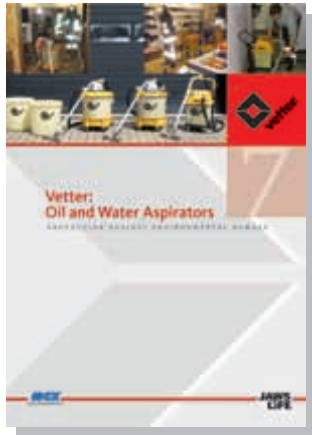
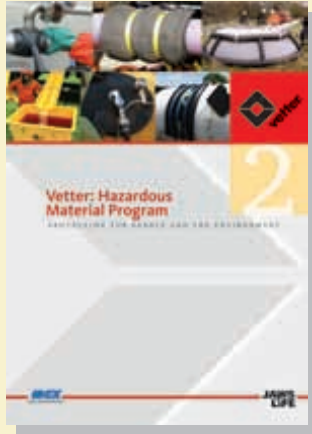

Further Vetter product catalogues are in preparation

Vetter: Industry

Vetter: Mobile Inspection Service

# CONTENTS

## Aircraft Lifting Bags

Recovery sets for the A 380

2

Aircraft Lifting Bags

## Aircraft Lifting Bags 1.0 bar/14.5 psi

System accessories ALB 1.0 bar/14.5 psi

5  
7

ALB  
1.0 bar/14.5 psi

## Aircraft Lifting Bags 5/120 NG 0.5 bar/7.25 psi

8

ALB 5/120 NG  
0.5 bar/7.25 psi

## Aircraft Lifting Bags 0.5 bar/7.25 psi

System accessories ALB 0.5 bar/7.25 psi

10  
12

ALB  
0.5 bar/7.25 psi

## Vetter categories

14

Vetter  
categories

## Contour matching

16

Contour matching

## Recovery accessories

Combination traverse CAT I/II

19

Traverse CAT III

20

Looping systems

21

Cable tension device

22

Tensile strength measurement gauges

22

Compressors

23

Recovery accessories

## Resistance charts and material charts

24

Resistance charts and  
material charts

# Vetter Aircraft Lifting Bags – Recovery sets for the A 380



The two differing recovery systems for the Airbus A 380 are especially characterized by the following features:

- 1.0 bar (14.5 psi) technology
- this achieves increased stability
- a coupling system easy to use
- individual system for contour matching
- 2 new ALB (Type 30/380 and Type 60/400)

Alternatively, these two sets can be supplied in the field-proven design:

- with an operating pressure of 0.5 bar (7.25 psi)
- this makes it suitable as an upgrade for the existing systems
- equipped with stable claw couplings
- with corresponding contour matching system

ALB 30/380

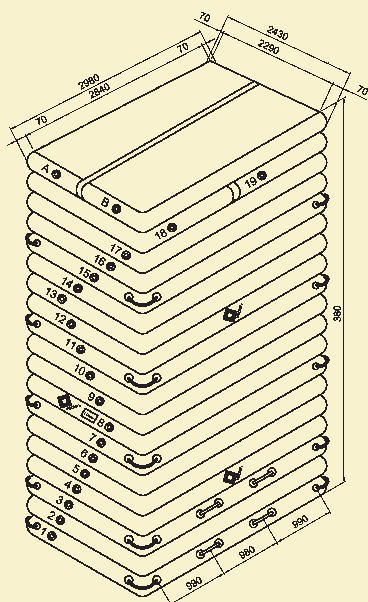

ALB 60/400

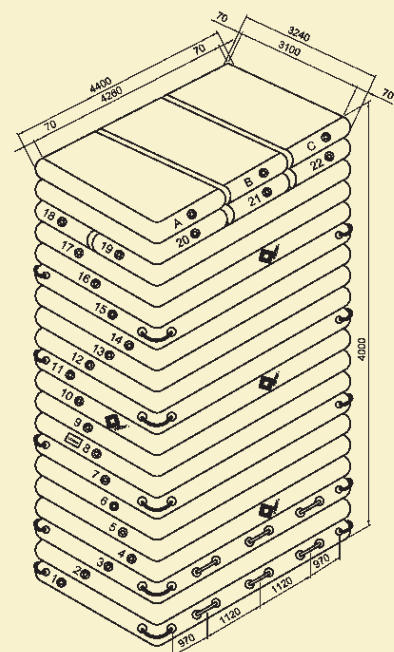

**Top view**

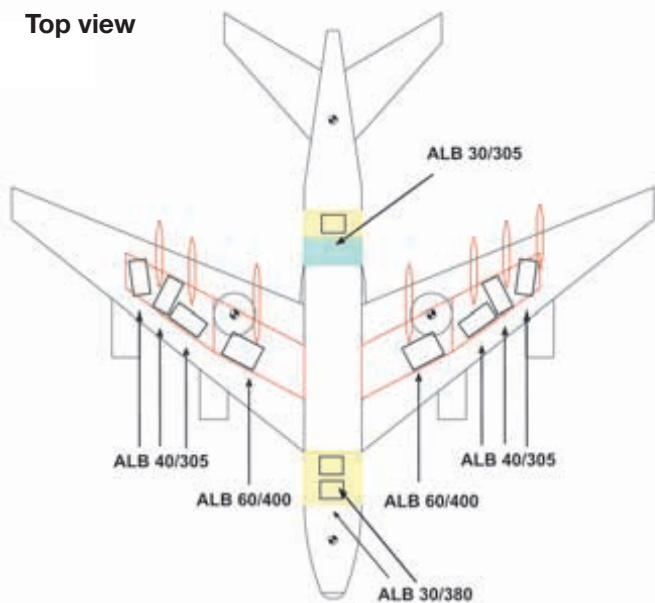

Set combination Cat. A 380 I

**Top view**

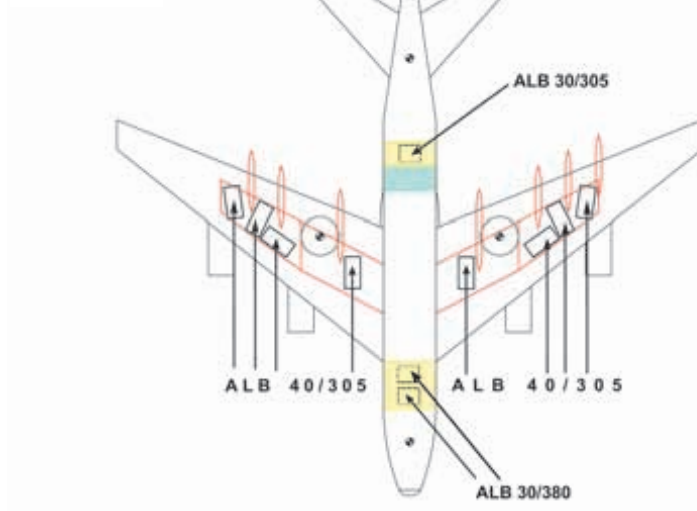

Set combination Cat. A 380 II

Table of sets I and II – Recovery systems for A 380 1.0 bar/0.5 bar (14.5 psi/7.25 psi)

Art.-No.	Description	Cat. A 380 I 1.0 bar/ 14.5 Psi	Cat. A 380 II 1.0 bar/ 14.5 Psi	Cat. A 380 I 0.5 bar/ 7.25 Psi	Cat. A 380 II 0.5 bar/ 7.25 Psi
3510001200	Set ALB 30/305 1.0 bar/14.5 psi	1	1		
3510001700	Set ALB 30/380 1.0 bar/14.5 psi	2	2		
3510001300	Set ALB 40/305 1.0 bar/14.5 psi	6	8		
3510001400	Set ALB 60/400 1.0 bar/14.5 psi	2			
3500006600	Set ALB 30/305 0.5 bar/7.25 psi			1	1
3500007500	Set ALB 30/380 0.5 bar/7.25 psi			2	2
3500004700	Set ALB 40/305 0.5 bar/7.25 psi			6	8
3500001000	Set ALB 60/400 0.5 bar/7.25 psi			2	
	<b>Optional: contour matching</b>				
3500005000	Set 30 t	2	2	2	2
3500005100	Set 40 t	3	6	3	6
3500007200	Set 60 t	2		2	

The accessories, such as inflation hose, controller, pressure valve, traverse, are individually combinable.

**Front view**

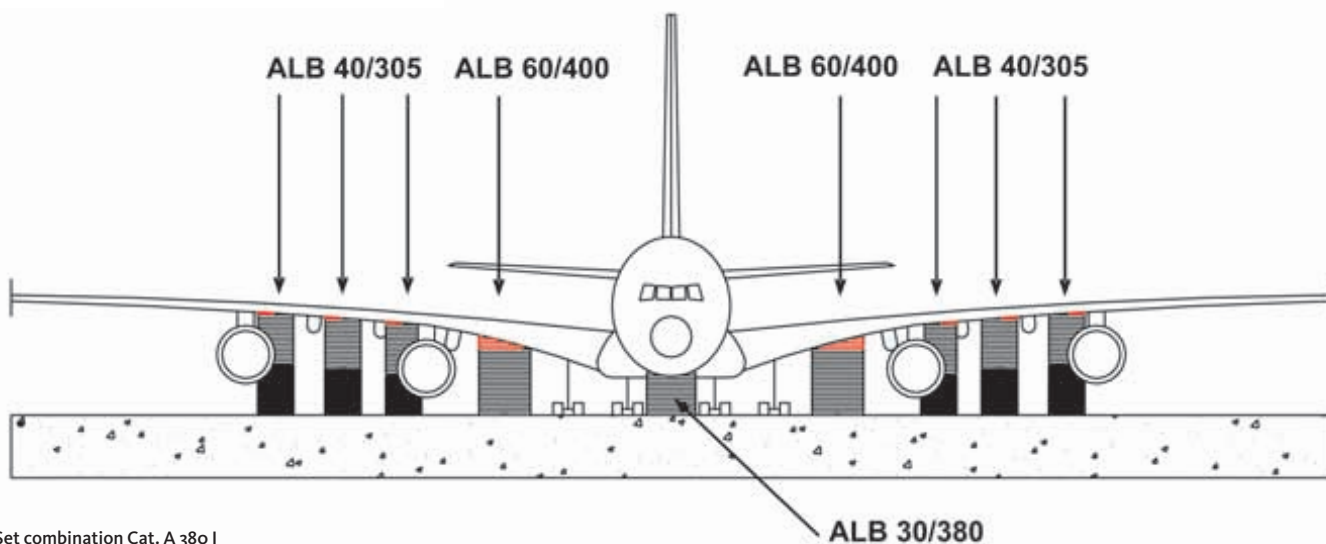

Set combination Cat. A 380 I

## Front view

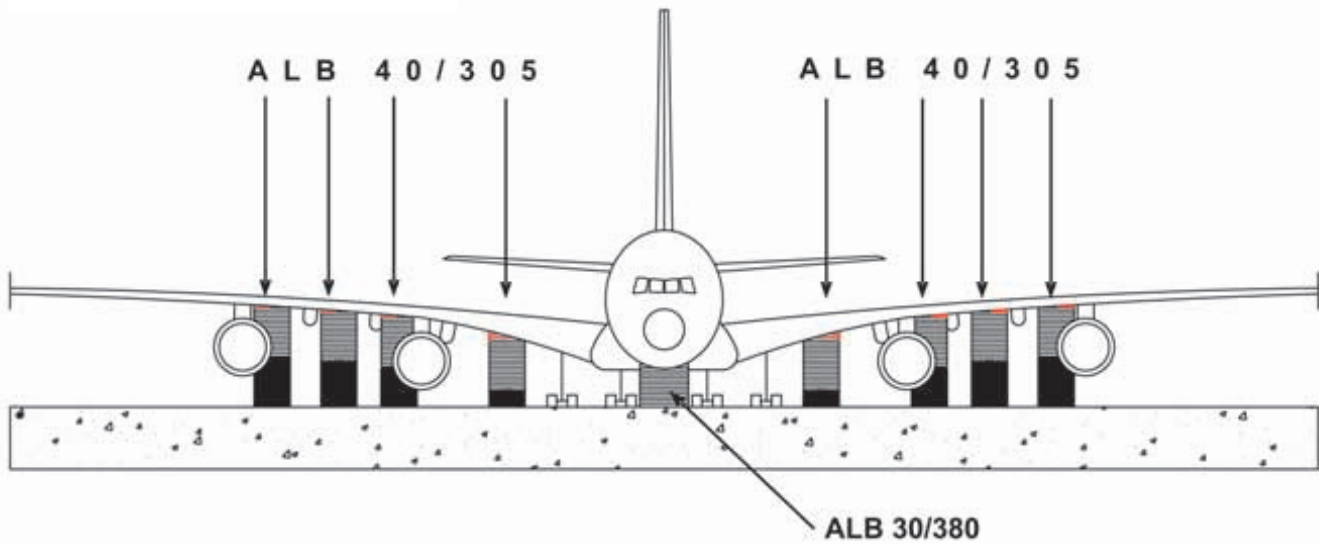

Set combination Cat. A 380 II

The table below gives the technical data for the Aircraft Lifting Bags contained in the recovery sets for the Airbus A 380.

### Technical data ALB 1.0 bar/14.5 psi for the A 380

### Technical data ALB 0.5 bar/7.25 psi for the A 380

	Unit	ALB 30/305	ALB 30/380	ALB 40/305	ALB 60/400	ALB 30/305	ALB 30/380	ALB 40/305	ALB 60/400
Art.-No.		3510000500	3510001500	3510000600	3510000700	3500004600	3500007300	3500004700	3500005500
Lift power	t	65.0	65.0	87.4	132.0	32.5	32.5	43.7	66.0
	lbs	71.7	71.7	96.4	145.6	33.5	33.5	48.2	72.8
Max. lifting height	cm	305	380	305	400	305	380	305	400
	inch	120	150	120	157	120	150	120	157
Lifting bag chambers		17	21	20	25	17	21	20	25
Support area (LxW)	cm	284 x 229	284 x 229	426 x 205	426 x 310	284 x 229	284 x 229	426 x 205	426 x 310
	inch	112 x 90	112 x 90	168 x 81	168 x 122	112 x 90	112 x 90	168 x 81	168 x 122
Total area (LxW)	cm	298 x 243	298 x 243	440 x 219	440 x 324	298 x 243	298 x 243	440 x 219	440 x 324
	inch	117 x 96	117 x 96	173 x 86	173 x 128	117 x 96	117 x 96	173 x 86	173 x 128
Insertion height (deflated bag)	cm	20	20	20	25	20	20	20	25
	inch	7.9	7.9	7.9	9.8	7.9	7.9	7.9	9.8
Operating pressure	bar	1.0	1.0	1.0	1.0	0.5	0.5	0.5	0.5
	psi	14.5	14.5	14.5	14.5	7.25	7.25	7.25	7.25
Test pressure	bar	1.5	1.5	1.5	1.5	0.65	0.65	0.65	0.65
	psi	21.75	21.75	21.75	21.75	9.40	9.40	9.40	9.40
Nominal capacity	l	20,425	24,650	29,087	59,266	20,425	24,650	29,087	59,266
	cu.ft.	721	870	1,027	2,092	721	870	1,027	2,092
Air requirement	l	40,850	36,975	58,174	118,532	30,638	36,975	43,631	88,900
	cu.ft.	1,442	1,740	2,054	4,184	1,081	1,305	1,540	3,138
Packing dimensions of the bag (LxWxH)	cm	268 x 109 x 100	268 x 109 x 100	268 x 109 x 100	360 x 160 x 120	268 x 109 x 100	268 x 109 x 100	268 x 109 x 100	360 x 160 x 120
	inch	106 x 43 x 39	106 x 43 x 39	106 x 43 x 39	142 x 63 x 47	106 x 43 x 39	106 x 43 x 39	106 x 43 x 39	142 x 63 x 47
Dimensions of the packing bag (LxWxH)	cm	240 x 95 x 65	240 x 100 x 70	240 x 100 x 70	340 x 100 x 80	240 x 95 x 65	240 x 100 x 70	240 x 100 x 70	340 x 100 x 80
	inch	95 x 37 x 26	95 x 39 x 28	95 x 39 x 28	134 x 39 x 32	95 x 37 x 26	95 x 39 x 28	95 x 39 x 28	134 x 39 x 32
Approximate weight	kg	320	380	480	840	320	380	480	840
	lbs	706	838	1,058	1,852	706	838	1,058	1,852
Approximate weight of set	kg	513	588	681	1,155	513	588	681	1,155
	lbs	1,131	1,297	1,502	2,547	1,131	1,297	1,502	2,547

All rights reserved for technical changes

## Vetter Aircraft Lifting Bags 1.0 bar/14.5 psi



Aircraft Lifting Bags  
1.0 bar/14.5 psi

Aircraft lifting bags are characterized by their sturdiness, strength, exceptional side stability and stability under load. In parallel to the existing series with an operating pressure of 0.5 bar/7.25 psi, the product program was extended to a second construction series (having an operating pressure of 1.0 bar/14.5 psi).

As opposed to the 0.5 bar/7.25 psi series, the side stability of the 1.0 bar/14.5 psi series is increased by 40%.

In addition to the operating pressure and the increased side stability, another essential distinctive feature is the coupling system.

With the 1.0 bar/14.5 psi series, the ALB, hoses and controllers are fitted with rapid snap-in couplings, resp. nipples. This enables time-saving and easy inter-coupling of the individual elements.

Sizes and lifting heights are identical for both series, however the nominal lifting power for the 1.0 bar/14.5 psi series is double that of the other series.

This series also enables the divided top chambers to match to the aircraft contours.

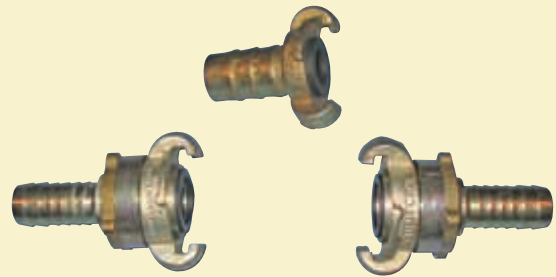

Coupling system 0.5 bar / 7.25 psi

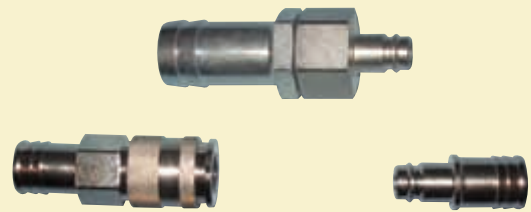

Coupling system 1.0 bar / 14.5 psi

### Advantages

- 40% higher stability against transverse forces
- easy and quickly useable coupling system
- optimum matching to the aircraft contours using divided contact chambers
- supplied as a fixed complete bag or as individual chamber
- space weave fabric avoids bulging of the top and bottom plates
- can be repaired
- long life duration of approximately 15 - 20 years

### Safety

- each ALB chamber has an integrated safety valve
- 2.5 times the bursting pressure to the operating pressure
- protection bushes on all connection nipples
- test pressure of 1.5 bar (21.75 psi)
- highly tear-proof polyamide fabric
- resistive against oil and ozone

Set table ALB 1.0 bar/14.5 psi

Art.-No.	Description	Art.-No. 3510000800 ALB 3/100	Art.-No. 3510001000 ALB 14/160	Art.-No. 3510001100 ALB 30/245	Art.-No. 3510001200 ALB 30/305	Art.-No. 3510001700 ALB 30/380	Art.-No. 3510001300 ALB 40/305	Art.-No. 3510001400 ALB 60/400
3510000100	ALB 3/100	1						
3510000300	ALB 14/160		1					
3510000400	ALB 30/245			1				
3510000500	ALB 30/305				1			
3510001500	ALB 30/380					1		
3510000600	ALB 40/305						1	
3510000700	ALB 60/400							1
0350012500	Padded plate 10 mm/0.4 inch for ALB 3/100	1						
0350018900	Padded plate 10 mm/0.4 inch for ALB 14/160		1					
0350001500	Padded plate 10 mm/0.4 inch for ALB 30/...			1	1	1		
0350001800	Padded plate 10 mm/0.4 inch for ALB 40/305						1	
0350025100	Padded plate 10 mm/0.4 inch for ALB 60/400							1
0350000800	Packing bag for ALB 3/100	1						
0350001000	Packing bag for ALB 14/160		1					
0350001300	Packing bag for ALB 30/...			1	1	1		
0350001600	Packing bag for ALB 40/305						1	
0350025500	Packing bag for ALB 60/400							1
0350017400	Transport box ALB 3/100	1						
0350017300	Transport box ALB 14/160		1					
0350016800	Transport box ALB 30/... and 40/...			1	1	1	1	
0350017800	Transport box ALB 60/400							1
0050004500	Repair material ALB	1	1	1	1	1	1	1

Technical data ALB 1.0 bar/14.5 psi

Art.-No.	Unit	ALB 3/100	ALB 5/120	ALB 14/160	ALB 30/245	ALB 30/305	ALB 30/380	ALB 40/305	ALB 60/400
		3510000100	3510000200	3510000300	3510000400	3510000500	3510001500	3510000600	3510000700
Nominal lift power	t	6.6	11.2	28.0	65.0	65.0	65.0	87.4	132.0
	lbs	7.3	12.4	30.9	71.7	71.7	71.7	96.4	145.6
Max. lifting height	cm	100	120	160	245	305	380	305	400
	inch	39	47	63	96	120	150	120	157
Lifting bag chambers		5	6	8	14	17	21	20	25
Support area (LxW)	cm	98 x 68	140 x 80	200 x 140	284 x 229	284 x 229	284 x 229	426 x 205	426 x 310
	inch	39 x 27	55 x 32	79 x 55	112 x 90	112 x 90	112 x 90	168 x 81	168 x 122
Total area (LxW)	cm	112 x 82	154 x 94	214 x 154	298 x 243	298 x 243	298 x 243	440 x 219	440 x 324
	inch	44 x 32	61 x 37	84 x 61	117 x 96	117 x 96	117 x 96	173 x 86	173 x 128
Insertion height (deflated bag)	cm	7	8	10	15	20	20	20	25
	inch	2.8	3.1	3.9	6.0	7.9	7.9	7.9	9.8
Operating pressure	bar	1.0	1.0	1.0	1.0	1.0	1.0	1.0	1.0
	psi	14.5	14.5	14.5	14.5	14.5	14.5	14.5	14.5
Test pressure	bar	1.5	1.5	1.5	1.5	1.5	1.5	1.5	1.5
	psi	21.75	21.75	21.75	21.75	21.75	21.75	21.75	21.75
Nominal capacity	l	861	1,698	5,309	16,340	20,425	24,650	29,087	59,266
	cu.ft.	30	60	187	577	721	870	1,027	2,092
Air requirement at 1.0 bar/14.5 psi	l	1,722	3,396	10,618	32,680	40,850	36,975	58,174	118,532
	cu.ft.	60	120	374	1,154	1,442	1,740	2,054	4,184
Packing dimensions of the box (LxWxH)	cm	113 x 48 x 60	115 x 123 x 61	178 x 63 x 75	268 x 109 x 100	268 x 109 x 100	268 x 109 x 100	268 x 109 x 100	360 x 160 x 120
	inch	45 x 19 x 24	45 x 48 x 24	70 x 25 x 30	106 x 43 x 39	106 x 43 x 39	106 x 43 x 39	106 x 43 x 39	142 x 63 x 47
Dimensions of the packing bag (LxWxH)	cm	110 x 30 x 40	110 x 40 x 40	170 x 55 x 45	240 x 90 x 60	240 x 95 x 65	240 x 100 x 70	240 x 100 x 70	340 x 100 x 80
	inch	43 x 12 x 16	43 x 16 x 16	67 x 22 x 18	95 x 35 x 24	95 x 37 x 26	95 x 39 x 28	95 x 39 x 28	134 x 39 x 32
Approximate weight	kg	26	41	93	256	320	380	480	840
	lbs	57	90	205	564	706	838	1,058	1,852
Approximate weight of set	kg	68	207	185	450	513	588	681	1,155
	lbs	150	456	408	993	1,131	1,297	1,502	2,547

All rights reserved for technical changes

## Systematic Safety. Vetter System Accessories – Aircraft Lifting Bags 1.0 bar/14.5 psi

### Inflation hose 1.0 bar/14.5 psi



Art.-No. 0350007401  
ALB compressed air hose,  
1.0 bar, 10 m  
(14.5 psi/ 32 ft.), yellow

### Inflation hoses 1.0 bar/14.5 psi including transport and storage box



Art.-No. 0351001100  
Set of inflation hoses,  
20 pieces



Art.-No. 0351001200  
Set of inflation hoses,  
30 pieces



Art.-No. 0351001300  
Set of inflation hoses,  
40 pieces



Art.-No. 3500001500  
Hose roller in box

### Controller fitting 1.0 bar/14.5 psi including transport and storage box

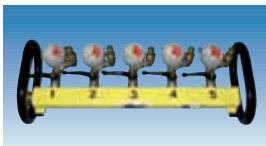

Art.-No. 0351000100  
5-section ALB controller,  
fitting

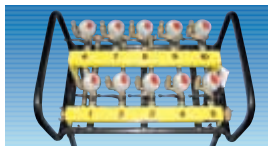

Art.-No. 0351000200  
10-section ALB controller,  
fitting

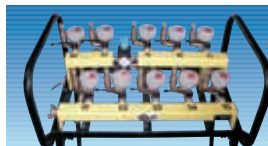

Art.-No. 0351000300  
10-section ALB controller,  
fitting with 3 contour chamber  
controllers



Art.-No. 0351000400  
(without picture)  
17-section ALB controller,  
fitting with 2 contour chamber  
controllers



Art.-No. 0351000500  
(without picture)  
17-section ALB controller,  
fitting with 3 contour chamber  
controllers

### Dead man controller 1.0 bar/14.5 psi including transport and storage box



Art.-No. 0351000700  
10-section ALB controller,  
dead man



Art.-No. 0351000600  
10-section ALB controller,  
dead man with 3 contour  
chamber controllers



Art.-No. 0351000800  
17-section ALB controller,  
dead man with 3 contour  
chamber controllers



Art.-No. 0351000900  
17-section ALB controller,  
dead man with 2 contour  
chamber controllers

### Compressed air distributor



Art.-No. 0351001400  
Compressed air distributor,  
1 input, 6 blockable outputs

### Vacuum adapter for deflation of ALB



Art.-No. 0351001500  
Vacuum adapter including  
high power damping device

### Compressors



Art.-No. 0350006600  
Screw compressor Type 7/31

Art.-No. 0350007100  
Screw compressor Type 7/41

Art.-No. 0350019900  
(without picture)  
Build-in generator



Art.-No. 0350006700  
Aftercooler with condensed  
water distributor  
for screw compressors  
Type 7/31 and 7/41



Art.-No. 0350006800  
Afterfilter combination  
according to ZTV-SIB 90  
for screw compressors  
Type 7/31 and 7/41



Art.-No. 0350029100  
Compressor,  
petrol drive 200

## Vetter Aircraft Lifting Bags 5/120 NG 0.5 bar/7.25 psi

This compact set enables material protective recovery of aircraft when normal recovery equipment cannot be used. Their prime purpose is to produce free space underneath the aircraft so that suitable devices can be used for recovery operations.

Due to its lifting power of 5.6 t and a lifting height of 120 cm (47.2 inch), this set is suitable for use on light aircraft as well as on business aircraft and Lear jets. The number of lifting bag sets and the type of equipment is mainly dependent on the type of aircraft to be recovered and its position.

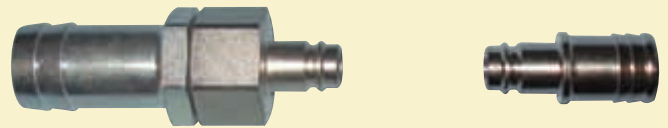

Hose coupling/nipple

In the transport and storage box there is an integrated 6-section controller with dead man switching as well as the corresponding inflation hoses and an air supply hose in addition to the ALB.

An essential advantage of the compact set is the ingeniously easy-to-use coupling system.

### Advantages

- ready-to-use unit in the transport and storage box
- each chamber can be individually controlled and checked
- ingeniously easy-to-use coupling system
- space weave of the fabric avoids bulging of top and bottom plates
- can be repaired
- life duration approximately 15 - 20 years

### Safety

- controller with dead man switching
- 4 times the bursting pressure to the operating pressure
- protection bushes on all connection nipples
- 1.3 times the test pressure to the operating pressure
- exceptionally sturdy and abrasion-proof fabric coating
- resistive against oil and ozone

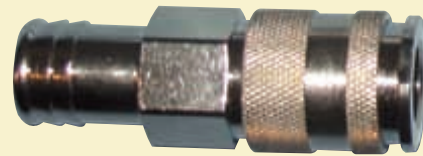

Connection nipple for ALB

ALB 5/120 NG  
0.5 bar/7.25 psi

ALB 5/120 NG

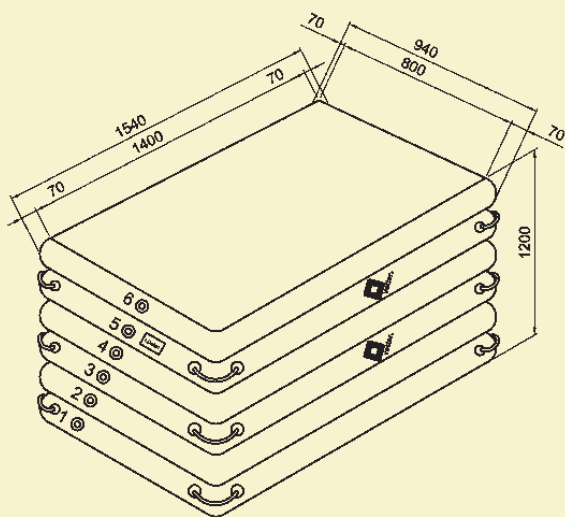

Technical data for ALB 5/120 NG

	Unit	ALB 5/120 NG
Art.-No.		3500004901
Lift power	t lbs	5.6 6.2
Max. lifting height	cm inch	120 47
Lifting bag chambers		6
Support area (LxW)	cm inch	140 x 80 55 x 32
Total area (LxW)	cm inch	154 x 94 61 x 37
Insertion height (deflated bag)	cm inch	8 3
Operating pressure	bar psi	0.5 7.25
Test pressure	bar psi	0.65 9.40
Nominal capacity	i cu.ft.	1,698 60
Air requirement	l cu.ft.	2,550 90
Packing dimensions of the box (LxWxH)	cm inch	115 x 123 x 61 45 x 48 x 24
Dimensions of the packing bag (LxWxH)	cm inch	110 x 40 x 40 43 x 16 x 16
Approximate weight	kg lbs	29 64
Approximate weight of set	kg lbs	195 430

Set table for ALB 5/120 NG

Art.-No.	Description	Art.-No. 3500005201 Set ALB 5/ 120 NG
3500004901	ALB 5/120 NG 0.5 bar/7.25 psi	1
0350025400	6-section ALB controller, 0.5 bar/7.25 psi, dead man, aluminium	1
0350007401	ALB compressed air hose, 0.5 bar, 10 m (7.25 psi/32 ft.), yellow	6
0350007801	ALB air supply hose, 10 m (32 ft.), red	1
0350024300	Padded plate, 10 mm/0.4 inch	1
0050016700	Set of repair material	1
0350024900	Packing bag ALB 5/120	1
0350025000	Transport and storage box 115x123x61 cm/45x48x24 inch	1

All rights reserved for technical changes

## Vetter Aircraft Lifting Bags 0.5 bar/7.25 psi



The pneumatic aircraft lifting bags are designed so that their surfaces softly position to the contours of the aircraft and the pressure is optimally distributed over it. With a maximum insertion height of 25 cm (10 inch) and a bag area of up to 14 m<sup>2</sup> the ALB are ideally suited to lift aircraft evenly up to 4 m/13 ft. (without any support from underneath).

The strong lifting power of up to 60 tons per bag and the enormous side stability, due to the space weave fabric having thousands of individual threads per square metre, ensure safe recovery.

Some of the essential characteristics of the modified ALB are a size matching related to the positioning area as well as the addition of 3 new sizes (refer to Technical Data).

The ALB are manufactured in 8 standard sizes.

ALB 30/305

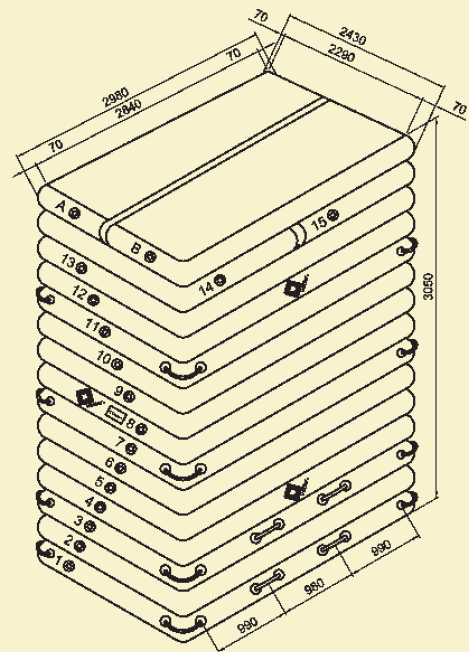

### Advantages

- each chamber can be individually controlled and checked
- extensive range of accessories
- divided top chambers enable matching to the contours of the aircraft
- supplied as a fixed connected complete bag or as individual chamber
- space weave of the fabric avoids bulging of top and bottom plates
- can be repaired
- life duration approximately 15 - 20 years

### Safety

- automatic pressure monitoring of the contour chambers
- all controllers are fitted with safety valves and manometers
- 4 times the bursting pressure to the operating pressure
- protection bushes on all connection couplings
- 1.3 times the test pressure to the operating pressure
- exceptionally sturdy and abrasion-proof fabric coating
- resistive against oil and ozone

Set table ALB 0.5 bar / 7.25 psi

Art.-No.	Description	Art.-No. 350000300 ALB 3/100	Art.-No. 350000400 ALB 14/160	Art.-No. 350000450 ALB 30/245	Art.-No. 350000600 ALB 30/305	Art.-No. 350000700 ALB 30/380	Art.-No. 350000800 ALB 40/305	Art.-No. 350001000 ALB 60/400
3500004300	ALB 3/100	1						
3500004400	ALB 14/160		1					
3500004500	ALB 30/245			1				
3500004600	ALB 30/305				1			
3500007300	ALB 30/380					1		
3500004700	ALB 40/305						1	
3500005500	ALB 60/400							1
0350012500	Padded plate 10 mm / 0.4 inch for ALB 3/100	1						
0350018900	Padded plate 10 mm / 0.4 inch for ALB 14/160		1					
0350001500	Padded plate 10 mm / 0.4 inch for ALB 30/ ...			1	1	1		
0350001800	Padded plate 10 mm / 0.4 inch for ALB 40/305						1	
0350025100	Padded plate 10 mm / 0.4 inch for ALB 60/400							1
0350000800	Packing bag for ALB 3/100	1						
0350001000	Packing bag for ALB 14/160		1					
0350001300	Packing bag for ALB 30/...			1	1	1		
0350001600	Packing bag for ALB 40/305						1	
0350025500	Packing bag for ALB 60/400							1
0350017400	Transport box ALB 3/100	1						
0350017300	Transport box ALB 14/160		1					
0350016800	Transport box ALB 30/... and 40/...			1	1	1	1	
0350017800	Transport box ALB 60/400							1
0050004500	Repair material ALB	1	1	1	1	1	1	1

Technical data ALB 0.5 bar/7.25 psi

Art.-No.	Unit	ALB 3/100	ALB 14/160	ALB 30/245	ALB 30/305	ALB 30/380	ALB 40/305	ALB 60/400
		3500004300	3500004400	3500004500	3500004600	3500007300	3500004700	3500005500
Lift power	t	3.3	14.0	32.5	32.5	32.5	43.7	66.0
	lbs	3.6	15.4	33.5	33.5	33.5	48.2	72.8
Max. lifting height	cm	100	160	245	305	380	305	400
	inch	39	63	96	120	150	120	157
Lifting bag chambers		5	8	14	17	21	20	25
Support area (LxW)	cm	98 x 68	200 x 140	284 x 229	284 x 229	284 x 229	426 x 205	426 x 310
	inch	39 x 27	79 x 55	112 x 90	112 x 90	112 x 90	168 x 81	168 x 122
Total area (LxW)	cm	112 x 82	214 x 154	298 x 243	298 x 243	298 x 243	440 x 219	440 x 324
	inch	44 x 32	84 x 61	117 x 96	117 x 96	117 x 96	173 x 86	173 x 128
Insertion height (deflated bag)	cm	7	10	15	20	20	20	25
	inch	2.8	3.9	6.0	7.9	7.9	7.9	9.8
Operating pressure	bar	0.5	0.5	0.5	0.5	0.5	0.5	0.5
	psi	7.25	7.25	7.25	7.25	7.25	7.25	7.25
Test pressure	bar	0.65	0.65	0.65	0.65	0.65	0.65	0.65
	psi	9.40	9.40	9.40	9.40	9.40	9.40	9.40
Nominal capacity	l	861	5,309	16,340	20,425	24,650	29,087	59,266
	cu.ft.	30	187	577	721	870	1,027	2,092
Air requirement at 0.5 bar/7.25 psi	l	1,292	7,964	24,510	30,638	36,975	43,631	88,900
	cu.ft.	46	281	865	1,081	1,305	1,540	3,138
Packing dimensions of the box (LxWxH)	cm	113 x 48 x 60	178 x 63 x 75	268 x 109 x 100	268 x 109 x 100	268 x 109 x 100	268 x 109 x 100	360 x 160 x 120
	inch	45 x 19 x 24	70 x 25 x 30	106 x 43 x 39	106 x 43 x 39	106 x 43 x 39	106 x 43 x 39	142 x 63 x 47
Dimensions of the packing bag (LxWxH)	cm	110 x 30 x 40	170 x 55 x 45	240 x 90 x 60	240 x 95 x 65	240 x 100 x 70	240 x 100 x 70	340 x 100 x 80
	inch	43 x 12 x 16	67 x 22 x 18	95 x 35 x 24	95 x 37 x 26	95 x 39 x 28	95 x 39 x 28	134 x 39 x 32
Approximate weight	kg	26	93	256	320	380	480	840
	lbs	57	205	564	706	838	1,058	1,852
Approximate weight of set	kg	68	185	450	513	588	681	1,155
	lbs	150	408	993	1,131	1,297	1,502	2,547

All rights reserved for technical changes

## Systematic Safety. Vetter System Accessories – Aircraft Lifting Bags 0.5 bar / 7.25 psi

### Inflation hose 0.5 bar/7.25 psi

### Inflation hoses 0.5 bar/7.25 psi including transport and storage box



Art.-No. 0350007301  
ALB compressed air hose,  
0.5 bar, 10 m  
(7.25 psi/32 ft.), yellow



Art.-No. 0350000800  
Set of inflation hoses,  
20 pieces



Art.-No. 0350007900  
Set of inflation hoses,  
30 pieces



Art.-No. 0350007200  
Set of inflation hoses,  
40 pieces



Art.-No. 3500001500  
Hose roller in box

### Controller fitting 0.5 bar/7.25 psi including transport and storage box

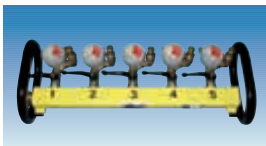

Art.-No. 0350002700  
5-section ALB controller,  
fitting

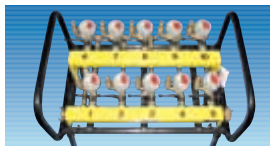

Art.-No. 0350002900  
10-section ALB controller,  
fitting

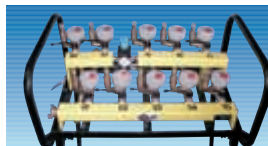

Art.-No. 0350003200  
10-section ALB controller,  
fitting with 3 contour chamber  
controllers



Art.-No. 0350005000  
(without picture)  
17-section ALB controller, fit-  
ting with 2 contour chamber  
controllers



Art.-No. 0350027700  
(without picture)  
17-section ALB controller,  
fitting with 3 contour chamber  
controllers

### Dead man controller 0.5 bar/7.25 psi including transport and storage box



Art.-No. 0350003800  
10-section ALB controller,  
dead man



Art.-No. 0350003400  
10-section ALB controller,  
dead man with 3 contour  
chamber controllers



Art.-No. 0350004200  
17-section ALB controller,  
dead man with 3 contour  
chamber controllers



Art.-No. 0350024800  
17-section ALB controller,  
dead man with 2 contour  
chamber controllers

### Compressed air distributor

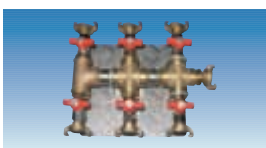

Art.-No. 0350005100  
Compressed air distributor,  
1 input, 6 blockable outputs

### Vacuum adapter for deflation of ALB



Art.-No. 0350005900  
Vacuum adapter including  
high power damping device

### Compressors



Art.-No. 0350006600  
Screw compressor Type 7/31

Art.-No. 0350007100  
Screw compressor Type 7/41

Art.-No. 0350019900  
(without picture)  
Build-in generator



Art.-No. 0350006700  
Aftercooler with  
condensed water distributor  
for screw compressors  
Type 7/31 and 7/41



Art.-No. 0350006800  
Afterfilter combination  
according to ZTV-SIB 90  
for screw compressors  
Type 7/31 and 7/41



Art.-No. 0350029100  
Compressor,  
petrol drive 200

## DESIGN AND DELIVERY PACKAGE

The ALB are basically designed for both series, 0.5 bar/7.25 psi and 1.0 bar/14.5 psi, as follows:  
The individual chambers are arranged numerically exactly the same as the related controllers, this ensures that there is clear allocation between controller and ALB chamber.

The divided top chambers, which are in direct contact with the aircraft contour, are marked alphabetically. The corresponding manometer and lever on the controller responsible for the control of these chambers are also marked alphabetically.

The delivery package of one set of ALB contains:

- 1 Aircraft Lifting Bag
- 1 Padded plate, 10 mm / 0.4 inch
- 1 Packing bag
- 1 Set of repair material
- 1 Transport and storage box

The only exception is the set ALB 5/120. This is supplied as a compact package and includes controller, inflation hoses and air supply hose.

## CONTROLLERS

With controllers one basically differentiates between a fitting design and a dead man switching design. The standard controllers are supplied as 5 section, 10 section or 17 section devices. There are two types of 10 section and 17 section controllers: the controller with contour chamber regulation and those without this facility. The controllers with contour chamber regulation have an adjustable pressure regulator integrated for 0.1 to 0.5 bar (1.45 to 7.25 psi) enabling constant pressure in the divided contact chambers. There are either 2 or 3 contact chambers depending on the size of the bag. In order to inflate the larger bags two controllers are connected together via a connection hose to form one unit owing to the number of chambers involved. For this, there is a controller without contour chamber regulation for the lower chambers and a controller with regulation for the upper chambers.



Fitting controller without contour chamber control

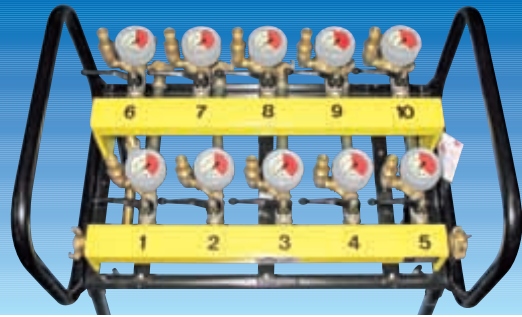

Dead man controller with contour chamber control



### Fitting controller

- supplied with 5 sections, 10 sections or 17 sections
- 10 section controller and 17 section controller with or without contour chamber control
- low in weight
- sturdy and little maintenance needed
- other sizes on request
- short inflation times

### Dead man controller

- available as 10 section controller and 17 section controller
- can be supplied with or without contour chamber control
- high quality glass-fibre reinforced housing
- dead man operation (automatic zero adjustment)
- various colours for the control levers thus achieving better distinction between contact chamber control (red) and control of the other chambers (black)
- low in weight

# Vetter Categories

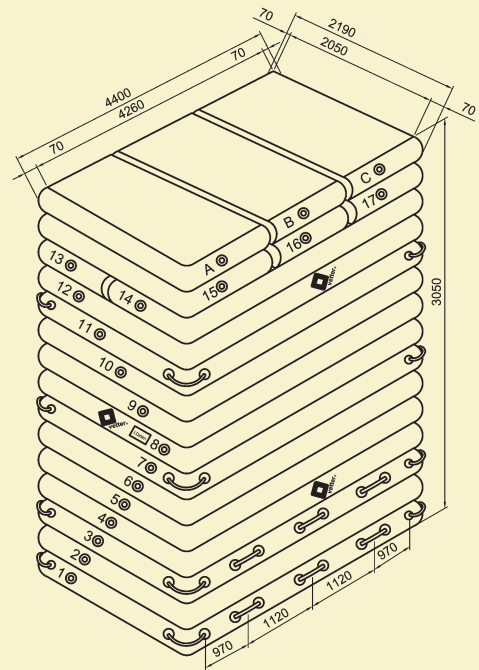

ALB 40/305

Set table for ALB categories 1.0 bar/14.5 psi

Art.-No.	Description	Cat. 5	Cat. 4	Cat. 3	Cat. 2	Cat. 1	Cat. A 380 I	Cat. A 380 II
3510001000	Set ALB 14/160	3						
3510001100	Set ALB 30/245		2	2	2	2		
3510001200	Set ALB 30/305		2	4	5	4	1	1
3510001700	Set ALB 30/380						2	2
3510001300	Set ALB 40/305					2	6	8
3510001400	Set ALB 60/400						2	
	<b>Inflation hoses</b>							
0351001100	Set of inflation hoses, 20 pcs.				1			
0351001300	Set of inflation hoses, 40 pcs.	1	2	3	3	4	8	8
	<b>Controllers (dead man alternative fitting)</b>							
0351000700	10 section ALB controller, 1.0 bar/14.5 psi, dead man	3				2	10	10
0351000200	10 section ALB controller, 1.0 bar/14.5 psi, fitting							
0351000600	10 section ALB controller, 1.0 bar/14.5 psi, dead man with 3 contour chamber controllers					2	6	8
0351000300	10 section ALB controller, 1.0 bar/14.5 psi, fitting with 3 contour chamber controllers							
0351000900	17 section ALB controller, 1.0 bar/14.5 psi, dead man with 2 contour chamber controllers		4	6	7	6	3	3
0351000400	17 section ALB controller, 1.0 bar/14.5 psi, fitting with 2 contour chamber controllers							
0351000800	17 section ALB controller, 1.0 bar/14.5 psi, dead man with 3 contour chamber controllers						2	
0351000500	17 section ALB controller, 1.0 bar/14.5 psi, fitting with 3 contour chamber controllers							
	<b>Compressed air distributors</b>							
0351001400	Compressed air distributor	1	1	1	2	2	4	4
	<b>Padded plates 30 mm / 1.2 inch</b>							
0350001100	Padded plate 30 mm for ALB 14/160	3						
0350001400	Padded plate 30 mm for ALB 30...		4	6	7	6	3	3
0350001700	Padded plate 30 mm for ALB 40/305					2	6	8
0350025200	Padded plate 30 mm for ALB 60/400						2	
	<b>Cable tension device</b>							
3500001900	Set for cable tension device	4	4	4	6	8	8	8
	<b>Other accessories</b>							
0350006600	Screw compressor Type 7/31	1	1	1				
0350007100	Screw compressor Type 7/41				1	1	1	1
0350006700	Aftercooler with condensed water distributor	1	1	1	1	1	1	1
0350006800	After-filter combination	1	1	1	1	1	1	1

## VETTER CATEGORIES 0.5 BAR AND 1.0 BAR (7.25 PSI AND 14.5 PSI)

The lifting power of the ALB are dependent on the pressure and the contact area (Power = Area x Pressure). The construction guarantees that the maximum lifting power is reached at an operating pressure of 0.5 bar/7.25 psi, resp. 1.0 bar/14.5 psi.

The question concerning the type of ALB to be used for recovery depends, among others, on the following factors:

- the type of aircraft to be recovered and its position
- the recovery weight of the aircraft
- according to the data specified in recovery manuals
- positioning areas for the ALB surfaces

The number of controllers is dependent on the number of chambers of the ALB. If the aircraft lifting bag has divided contact chambers (2 or 3) then when selecting the number of controllers it must be observed that one of the controllers has a contour chamber control (for 2 or 3 chambers).

The number of hoses is dependent on the size of the ALB being used as well as the number of chambers. In addition to this, a corresponding number of hoses will be required for the connection of compressors, air distributors and controllers.

Set table for ALB categories 0.5 bar/7.25 psi

Art.-No.	Description	Cell. 5	Cell. 4	Cell. 3	Cell. 2	Cell. 1	Cell. A 380 I	Cell. A 380 II
350000400	Set ALB 14/160	3						
350000500	Set ALB 30/245		2	2	2	2		
350000600	Set ALB 30/305		2	4	5	4	1	1
3500007500	Set ALB 30/380						2	2
350000800	Set ALB 40/305					2	6	8
350001000	Set ALB 60/400						2	
	<b>Inflation hoses</b>							
0350008000	Set of inflation hoses, 20 pcs.				1			
0350007200	Set of inflation hoses, 40 pcs.	1	2	3	3	4	8	8
	<b>Controllers (dead man alternative fitting)</b>							
0350003800	10 section ALB controller, 0.5 bar/7.25 psi, dead man	3				2	10	10
0350002900	10 section ALB controller, 0.5 bar/7.25 psi, fitting							
0350003400	10 section ALB controller, 0.5 bar/7.25 psi, dead man with 3 contour chamber controllers					2	6	8
0350003200	10 section ALB controller, 0.5 bar/7.25 psi, fitting with 3 contour chamber controllers							
0350024800	17 section ALB controller, 0.5 bar/7.25 psi, dead man with 2 contour chamber controllers		4	6	7	6	3	3
0350005000	17 section ALB controller, 0.5 bar/7.25 psi, fitting with 2 contour chamber controllers							
0350004200	17 section ALB controller, 0.5 bar/7.25 psi, dead man with 3 contour chamber controllers						2	
0350027700	17 section ALB controller, 0.5 bar/7.25 psi, fitting with 3 contour chamber controllers							
	<b>Compressed air distributors</b>							
0350005100	Compressed air distributor	1	1	1	2	2	4	4
	<b>Padded plates 30 mm / 1.2 inch</b>							
0350001100	Padded plate 30 mm for ALB 14/160	3						
0350001400	Padded plate 30 mm for ALB 30...		4	6	7	6	3	3
0350001700	Padded plate 30 mm for ALB 40/305					2	6	8
0350025200	Padded plate 30 mm for ALB 60/400						2	
	<b>Cable tension device</b>							
3500001900	Set for cable tension device	4	4	4	6	8	8	8
	<b>Other accessories</b>							
0350006600	Screw compressor Type 7/31	1	1	1				
0350007100	Screw compressor Type 7/41				1	1	1	1
0350006700	Aftercooler with condensed water distributor	1	1	1	1	1	1	1
0350006800	After-filter combination	1	1	1	1	1	1	1

# Vetter Contour matching

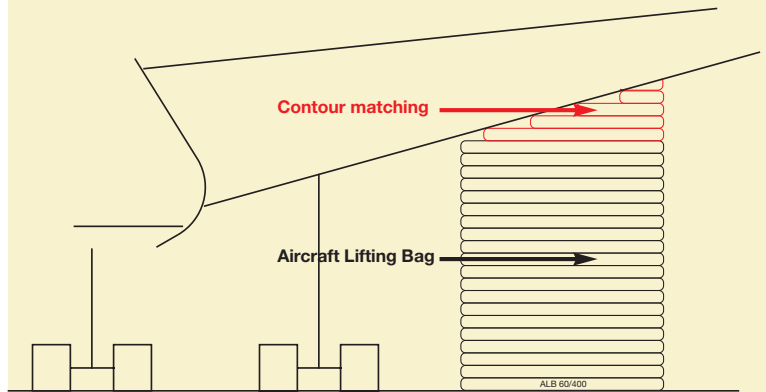

Contour matching can be carried out using two different methods:

- contour matching using contact chambers of the aircraft lifting bag
- contour matching using vacuum chambers

## CONTOUR MATCHING USING THE CONTACT CHAMBERS

The transverse and longitudinally arranged bag chambers enable optimum matching to the positioning surfaces, especially if the aircraft is positioned at an angle.

The foam rubber padded plate (10 mm/0.4 inch) is used as a protection against sharp-edged parts. A padded plate (30 mm/1.2 inch) can be additionally ordered.



## CONTOUR MATCHING USING VACUUM CHAMBERS

The increasing number of new aircraft fuselage and wing shapes make contour matching imperative in the field of aircraft recovery using pneumatic lifting bags. It was for this reason that Vetter GmbH further developed a field-proven recovery system in cooperation with the authorities at Frankfurt Airport which offers the following advantages:

- low pressure point loading on sensitive aircraft parts
- meets the specifications of the aircraft manufacturers
- high degree of stability
- high safety standard
- individual contour matching





Stabilization is made in a number of steps:

### Step 1

In the first step, a pneumatic aircraft lifting bag is positioned under the wings of the aircraft to be recovered.

### Step 2

In the second step, vacuum bags are positioned on the lifting bag facing the fuselage.

These vacuum bags are similar to vacuum mattresses used by rescue services and exactly match to the contours.

When a vacuum is then produced in the bags they will shape themselves to the contours and stabilize the aircraft.



Vacuum bags before contour matching



Vacuum bags after contour matching



### Step 3

In the third step large intermediate spaces are filled out with individual chamber bags, with dimensions of 50 x 230 cm (20 x 91 inch) and 100 x 230 cm (40 x 91 inch), which are blown up to the full operating pressure.

### Step 4

In the fourth and last step before the lifting procedure starts, the smaller intermediate spaces can be filled with filling sacks having dimensions of 40 x 60 cm (16 x 24 inch).

These sacks let the air through enabling contour matching and supporting of antennas, spindle drives and other protruding parts.



In order to meet the requirements of modern aircraft recovery, an existing ALB system can be extended for contour matching with the following accessories. The required quantities depend on the existing system.

Set table for contour matching

Art.-No.	Description	Art.-No. 3500005000 Set 30 to	Art.-No. 3500005100 Set 40 to	Art.-No. 3500007200 Set 60 to
350006400	ALB Chamber 500 x 2300 mm 0.5 bar (20 x 91 inch 7.25 psi)	6	9	12
350006300	ALB Chamber 1000 x 2300 mm 0.5 bar (40 x 91 inch 7.25 psi)	6	9	12
350004800	ALB Chamber 2270 x 1540 mm 0.5 bar (89 x 61 inch 7.25 psi)	3	6	9
350006100	ALB Chamber 1000 x 2300 mm (40 x 91 inch) <b>VACUUM</b>	7	10	13
0350007301	ALB compressed air hose 10 m (32 ft.), yellow, with screw coupling	20	30	40
0350007401	ALB compressed air hose 10 m (32 ft.), yellow, with snap-in coupling	10	15	20
0350022500	Base plate 2440 x 1250 mm (96 x 49 inch), 10 mm (0.4 inch) thick	3	4	6
0350003800	10 section ALB controller, 0.5 bar/7.25 psi, dead man	2	3	4
0350019800	8 section ALB controller VACUUM, dead man	1	2	2
0350022600	Filling sack 400 x 600 mm (16 x 24 inch), filled with Styropore	60	60	60
0350022700	Label set, numbering 1 - 25	2	2	2
0350022800	Label set, numbering 26 - 50	2	2	2
0350022900	Fold-up ladder, 12 steps	1	1	1
0350023000	Covering, 1.46 m (57 inch) folded out	1	1	1
0350005100	Compressed air distributor, 1 input, 6 blockable outputs	1	1	1

# Vetter Recovery accessories



## LIFTING HARNESS FOR ALL SIZES OF AIRCRAFT

The lifting harnesses are divided into three categories with which it is possible to recover all types of aircraft after landing gear failure. It consists of lifting straps, loop straps and various braces.

With braces one differentiates between:

- Combination brace CAT I and II
- Lifting brace CAT III

## COMBINATION BRACE CAT I AND CAT II

With the combination brace CAT I/II aircraft up to a recovery weight of 12,000 kg / 26,460 lbs (e.g. Learjet, Cessna) can be recovered. In doing this, adjustable transverse braces are used in connection with the girder brace.

With sole use of the girder brace the function radius of the combination brace is extended to aircraft with a fuselage circumference of 8 – 12 m / 26 – 38 ft. (e.g. 737, 757).

The delivery package of the set for the combination brace (Art. No. 0350020600) includes:

- 1 Combination brace
- 1 Set of lifting straps
- 1 Lifting band
- 1 Adhesion plate
- 2 Loop straps

The **combination brace** (Art. No. 0350011600) consists of:

- 1 girder brace with eye suspension, including two adjustment frames
- 2 adjustable transverse braces
- 4 adjustable single hooks



### Girder brace

Carrying weight:	12,000 kg (26,460 lbs)
Working width:	4,000 mm (157 inch)
Working height:	320 mm (12.6 inch)
Construction height:	1,700 mm (67 inch)
Own weight:	1,100 kg (2,426 lbs)
Min. adjustment range:	2,400 m (95 inch)
Max. adjustment range:	4,000 m (157 inch)
Ratchet:	200 mm (8 inch)



### Transverse brace

Carrying weight:	6,000 kg (13,230 lbs)
Min. adjustment range:	800 mm (31.5 inch)
Max. adjustment range:	2,400 mm (95 inch)
Ratchet:	100 mm (4 inch)



### Single hook

Carrying weight:	3,000 kg (6,615 lbs)
------------------	----------------------



**Set of lifting straps**  
(Art.-No. 0350008700)

With loop slings consisting of:

- 2 lifting straps, length: 3,000 mm (118 inch)
- 2 lifting straps, length: 5,000 mm (197 inch)
- 2 lifting straps, length: 7,000 mm (276 inch)

- Width: 240 mm (9.5 inch)
- Sling width, approx.: 45 mm (1.8 inch)
- Sling length, approx.: 400 mm (16 inch)
- Carrying weight (single direct): 3,000 kg (6,615 lbs)
- Carrying weight (single lay): 6,000 kg (13,230 lbs)



**Lifting strap**  
(Art.-No. 0350009100)

With two ready-made, reinforced loop straps, length: 800 mm/31.5 inch and two sown-on securing belts including storage pockets with clamp lock securing belt as well as coated straps for attachment of an adhesion plate.

- Width: 300 mm (12 inch)



**Adhesion plate**  
(Art.-No. 0350009200)

Velcro on the back.

- Length: 4,000 mm (157 inch)
- Width: 300 mm (12 inch)
- Thickness: 5 mm (0.2 inch)



**Loop straps**  
(Art.-No. 0350009500)

As an extension to the lifting strap CAT II

- Carrying weight (single direct): 4,000 kg (8,820 lbs)
- Carrying weight (single lay): 8,000 kg (17,640 lbs)
- Length: 3,000 mm (118 inch)

**LIFTING BRACE CAT III**

A complete recovery/lifting device for lifting aircraft up to a recovery weight of 24,000 kg / 52,920 lbs and with a fuselage circumference of 15 – 23 m / 48 ft. – 74 ft. (e.g. B 747, A340).

The delivery package for the lifting brace set (Art.-No. 0350020500) consists of the following items:

- 1 brace
- 1 lifting strap mat construction
- 2 plate triangular braces
- 2 loop straps





**Brace**  
Art.-No. 0350009800

Matched to recovery device  
incl. 2 single hooks

Length: 6,000 mm (236 inch)  
Carrying weight: 24,000 kg (52,920 lbs)



**Lifting strap mat construction**  
Art.-No. 0350006900

Consisting of:  
4 lifting straps, each 180 mm (7 inch) in width, connected by 4 cross straps to make a mat having a width of 1,680 mm (66 inch).  
Lifting straps are each fitted with 4 ready-made, reinforced carrying loops each having 2 ready-made lashing straps.

Total length: 14,000 mm (551 inch)  
Carrying weight (single lay): 24,000 kg (52,920 lbs)



**Plate triangular braces**  
Art.-No. 0350009700

With eye suspension, complete with stop buffers and 4 belt hooks with safety device.

Length: 1,740 mm (69 inch)  
Carrying weight: 12,000 kg (26,460 lbs)  
Eye height: 270 mm (11 inch)  
Eye width: 135 mm (5.3 inch)  
Construction height: 570 mm (22.4 inch)  
Weight: 200 kg (441 lbs)



**Loop with centre seam**  
(Art.-No. 0350009400)

Circumference length: 8,000 mm (315 inch)  
Laid out working length: 4,000 mm (157 inch)

Table of loops

Art.-No.	Description	Art.-No. 350009900 Set 20 to	Art.-No. 350010700 Set 12 to	Art.-No. 350010800 Set 4 to
0350010000	Tension loop, 20 m / 64 ft. long, 20 t	4		
0350010600	Tension loop, 15 m / 48 ft. long, 12 t		4	
0350010100	Lifting straps, 4 m / 13 ft., with lashing strap 8 t	2		
0350010200	Lifting straps, 3 m / 9.6 ft., with lashing strap 4 t	2	2	
0350010300	Lashing strap connector RAL 3000	6	6	
0350010400	Tensioning device (Rockinger 50 mm / 2 inch diameter)	1	1	
0350010500	Tensioning device (Schlepper 76 mm / 3 inch diameter)	1	1	
0350010900	Loop 3 m / 9.6 ft. long			2
0350011000	Loop 4 m / 13 ft. long			2
0350011100	Loop 5 m / 16 ft. long			2
0350011200	Loop 10 m / 32 ft. long			2
0350011300	Loop 15 m / 48 ft. long			2
0350011400	Loop 20 m / 64 ft. long			2

## TENSION DEVICE

The purpose of the tension device is to span the aircraft to be recovered and to ensure that it does not slip. The tensile strength of the tension device can be multiplied by reeving the cable according to the pulley block principle.

How the tension device operates

- The cable is held securely between both clamping jaws.
- Self-clamping mechanism – the loaded cable draws the clamping jaws together.
- When in the unloaded condition, the tension device can be freely switched – the cable can then be fed in by hand and tensioned, resp. taken out.



Set table for the tension device

Art.-No.	Description	Art.-No. 350001900 Set for tension device
3500002000	Tension device with lever tube, 3.2 t	1
3500002100	Cable 30 m/96 ft., 16 mm/0.6 inch diameter	1
3500002200	Cable strop 3 m/9.6 ft., wire	1
3500002300	Ground anchor (brackets, shackles, lugs)	2
3500002400	Tool box for tension device	1
0350017000	Transport and storage box for tension device	1

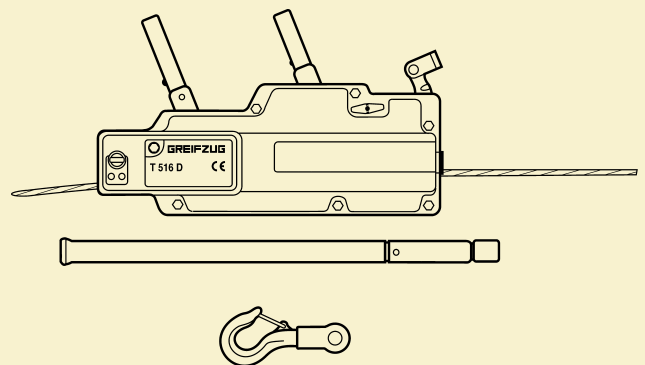

## TENSION MEASUREMENT GAUGES

These are instruments which monitor the tension when spanning or lifting during aircraft recovery. You can combine it with the load using a shackle as a direct suspension possibility.

The measurement gauges are equipped with an LCD display. The load can be displayed in kg, t, daN or kN.

Features

- Tare suppression over the complete measurement range
- Peak value indication as a standard
- Automatic zero setting when switching on
- Automatic switch-off for saving battery power
- Low current consumption – up to 250 operating hours with just one set of batteries
- Operation is made with a flat weather-proof membrane keypad on the front

Accessories

- 3500002900 shackle for tensile strength measurement gauge 5 t
- 3500003100 shackle for tensile strength measurement gauge 25 t
- 3500002700 remote display
- 3500002800 transfer cable to the remote display





Screw compressor 7/31 (Art.-No. 0350006600) or 7/41 (Art.-No. 0350007100)



Compressor drive 200 (Art.-No. 0350029100)

### Technical data for compressors

	Unit	7/31 E	7/41 E	Drive 200
Art.-No.		0350006600	0350007100	0350029100
Amount of air supply	m <sup>3</sup> /min	3	4	0.16
	cu.ft./min	106	141	0.01
Operating nominal pressure	bar	7	7	-
	psi	101.5	101.5	-
Operating pressure, max.	bar	8.6	8.6	10
	psi	124.7	124.7	145
Adjustment of over-pressure valve	bar	10	10	10
	psi	145	145	145
Number of cylinders		3	3	1
Rev. rate at full load	U/min	2,800	2,800	3,150
Power	kW	26.0	34.8	3.0
Electrics	Volt	12	12	-
Cooling		Water	Water	Air
Tank capacity	l	50	40	6
	cu.ft.	1.8	1.4	0.2
Air exhaust connections	BSPT	2 x 3/4"	2 x 3/4"	1 x 1/4"
Total length with fixed tension device	mm	2,923	2,972	-
	inch	115	117	-
Total length with adjustable tension device	mm	3,229 - 3,357	3,413 - 3,577	-
	inch	127 - 132	134 - 141	-
Total length	mm	-	-	520
	inch	-	-	21
Total width	mm	1,390	1,390	445
	inch	55	55	18
Height	mm	1,235	1,333	435
	inch	49	53	17
Free space of floor	mm	250	250	-
	inch	10	10	-
Empty weight with fixed/adjustable tension device	kg	595/610	650/700	-
	lbs	1,312/1,345	1,433/1,543	-
Operational weight with fixed/adjustable tension device	kg	635/650	685/735	-
	lbs	1,400/1,433	1,510/1,621	-
Weight	kg	-	-	22
	lbs	-	-	48.5

All rights reserved for technical changes

# Vetter

## List of resistance strengths and material

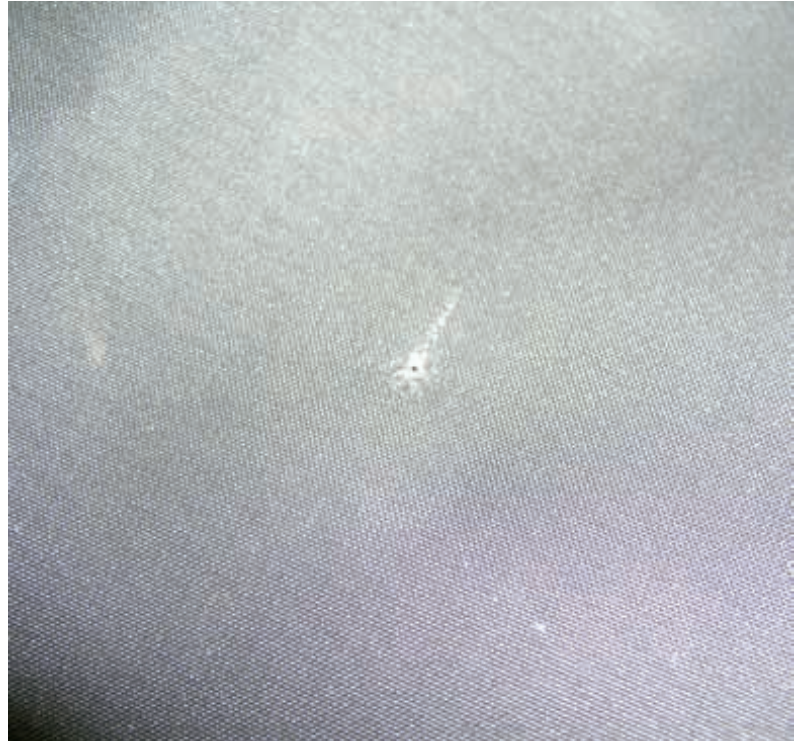

A tear in the surface layer caused by external mechanical influence

The durability of materials is mainly assessed according to their changes in mass and hardness with resistance examinations (DIN 53476 and 53521). The resistance of a rubber mixture is, depending on diffusion, essentially influenced by the thickness of the material being used. With most stresses there exists a combination of thermo-chemical affects and swelling.

A material being expanded reacts more quickly to chemicals as opposed to when it is in its normal state.

This means, the larger the expansion, the lower the chemical resistance. Therefore these lists of resistances can only be regarded as guides.

The data is taken from laboratory examinations as well as values obtained from experience and are influenced by such variable factors as: temperature, intensity, period of influence etc.

This list of resistances was made taking the above mentioned points into consideration and shown with the following symbols:

- + resistant
- o conditionally resistant
- non-resistant
- nd no details

The data shown here correspond to the present state of our know-how and should be regarded as guiding values.

We will gladly provide material samples should users wish to conduct their own chemical resistance tests.

Temperature resistance

Products	Cold resistance	Cold flexibility	Heat resistance long term	Heat resistance short term
Hot vulcanised	- 40° C	- 20° C	+ 90° C	+ 115° C
Cold vulcanised	- 40° C	- 20° C	+ 70° C	+ 85° C
NG	- 35° C	- 35° C	+ 80° C	+ 110° C
Rubber hoses	- 40° C	- 30° C	+ 90° C	
Packing bags	- 20° C		+ 50° C	
Packing covers	- 20° C		+ 50° C	
Controllers, fitting	- 20° C		+ 50° C	
Controllers, plastic	- 20° C		+ 50° C	
Controllers, aluminium	- 20° C		+ 50° C	

Material list

Products	Material	Support material	Manufacture
ALB 0.5/1.0 bar (7.25/14.5 psi)	CR	Aramide/Polyester	Cold vulcanised
ALB NG	NG	Polyester	Cold vulcanised
Packing bags for ALB	PVC	Polyester	-
Inflation hoses and air supply hoses	EPDM	Polyester	-

All rights reserved for technical changes



Surface in the new condition

Surface after incorrect storage

Resistance charts

Agent	CR	PVC	EPDM	NG
Aceton	o	-	-	-
Acetylene	+	o	-	-
Alum, watery	+	+	-	o
Aluminium chloride	+	o	+	+
Anilene	-	-	nd	o
ASTM Oil 1	o	nd	-	+
Petrol	o	-	nd	o
Benzene	-	-	-	o
Boric acid	+	+	+	+
Bromine (moist)	-	-	-	-
Butyric acid	-	o	nd	o
Chlorine gas (moist)	-	-	nd	-
Chlorine (wet)	o	nd	o	-
Diesel fuel	o	o	-	+
Iron chloride	+	+	+	+
Petroleum	o	o	-	+
Acetic acid	o	o	o	o
Fatty acid	+	nd	-	o
Formaldehyde	+	nd	+	-
Glukose	+	+	+	+
Heating oil	+	+	-	+
Potassium chloride	+	o	+	+
Calcium chloride	+	o	+	+

Agent	CR	PVC	EPDM	NG
Calcium nitrate	+	nd	+	+
Carbon dioxide	+	+	+	+
Carbon monooxide	+	-	+	+
Copper sulphate	+	o	+	+
Adhesive	+	nd	+	o
Methyl chloride	-	o	o	o
Sea water	+	o	nd	+
Mineral oil	+	+	-	+
Sodium carbonate	+	-	-	+
Ozone	+	nd	+	+
Paraffin	+	nd	-	+
Perchloric acid	o	nd	+	-
Phenol (watery)	-	-	+	-
Phosphoric acid (concentrated)	-	+	-	-
Mercury	+	o	+	+
Nitric acid (fuming)	-	+	-	-
Sulphur dioxide (dry)	-	o	nd	o
Sulphur acid (50%)	+	o	-	-
Nitrogen	+	nd	+	+
Carbon tetrachloride	-	o	-	-
Animal fat	+	nd	+	+
Toluene	-	-	-	-

Technical changes reserved!

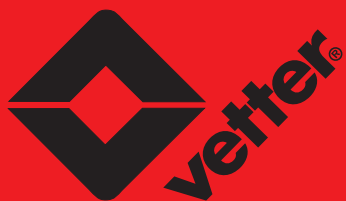

Vetter GmbH  
A Unit Of IDEX Corporation  
Blatzheimer Str. 10-12  
D-53909 Zülpich  
Fon +49 (0) 22 52/30 08-50  
Fax +49 (0) 22 52/30 08-70  
Fon Exp. +49 (0) 22 52/30 08-60  
Fax Exp. +49 (0) 22 52/30 08-71  
[www.vetter.de](http://www.vetter.de)  
[info@vetter.de](mailto:info@vetter.de)