

Double hose reel DSH-20

84150/5865-85 GB
Issue 03.2000

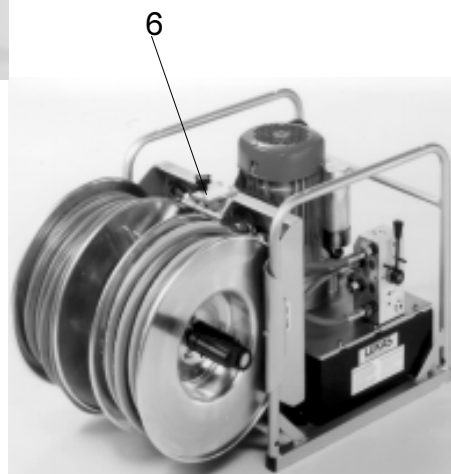
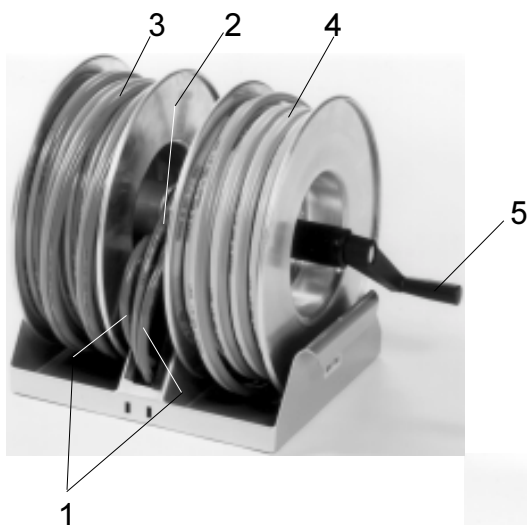

- 1 High pressure hose 0,7m, red
- 2 Return hose 0,7m, blue
- 3 Hose pair red/blue
- 4 Hose pair yellow/blue
- 5 Crank handle
- 6 Hose break

1 Basic operation and designated use of the machine

1.1 The machine has been built in accordance with state-of-the-art standards and the recognized safety rules. Nevertheless, its use may constitute a risk to life and limb of the user or of third parties, or cause damage to the machine and to other material property.

1.2 The machine must only be used in technically perfect condition in accordance with its designated use and the instructions set out in the operation manual, and only by safety-conscious persons who are fully aware of the risks involved in operating the machine. Any functional disorders, especially those affecting the safety of the machine/plant, should therefore be rectified immediately!

1.3 The machine is exclusively designed for the use described in the operating manual. Using the machine for purposes other than those mentioned in the manual, such as driving and controlling other pneumatic systems, is considered contrary to its designated use. The manufacturer/supplier cannot be held liable for any damage resulting from such use. The risk of such misuse lies entirely with the user.

Operating the machine within the limits of its designated use also involves observing the instructions set out in the operating manual and complying with the inspection and maintenance directives.

2 Organizational measures

2.1 The operating manual must always be at hand at the place of use of the machine!

2.2 In addition to the operating instructions, observe and instruct the user in all other generally applicable legal and other mandatory regulations relevant to accident prevention and environmental protection.

This also applies for wearing protective clothing, helmet with visor or goggles and protective gloves.

2.3 In order to avoid injuries, the machine must only be operated by a specially trained operator who has undergone a safety training.

2.4 Observe all safety instructions and warnings attached to the machine. Make sure that safety instructions and warnings attached to the machine are always complete and perfectly legible.

2.5 Never make any modifications, additions or conversions which might affect safety without the supplier's approval. This also applies to the installation and adjustment of safety devices and valves.

2.6 Spare parts must comply with the technical requirements specified by the manufacturer. Spare parts from original equipment manufacturers can be relied to do so. It is only allowed to use original LUKAS spare parts of LUKAS system components.

2.8 Adhere to prescribed intervals or those specified in the operating manual for routine checks and inspections.

2.9 Make sure to dispose properly of packing material and dismantled parts!

3 General safety instructions

3.1 In the event of malfunctions, stop the machine immediately and lock it. Have any defects rectified immediately.

3.2 Before starting up or setting the machine in motion and during operation of the machine make sure that nobody is at risk.

3.3 Before transporting the machine always check that the accessories have been safely stowed away.

3.4 Make sure that there is enough lighting during work.

3.5 Avoid any operation that might be a risk to machine stability.

3.6 Check the machine at least after every operation for obvious damage and defects. Report any changes (incl. changes in the machine's working behaviour) to the competent organization /person immediately. If necessary, stop the machine immediately and lock it. All lines, hoses and screwed connections have to be checked for leaks and obvious damage. Repair damage immediately. Splashed oil may cause injury and fire.

3.7 All safety equipment has to be checked for completeness and flawless condition:

- instruction markings and warning signs (safety instructions)
- check safety cover (e.g. motor-safety covers, heat protection etc.) if they are available and if they are in good condition.

4 Instructions for maintenance and service

4.1 For the execution of maintenance and service work, tools and workshop equipment adapted to the task on hand are absolutely indispensable.

Work on the hydraulic system must be carried out only by personnel having special knowledge and experience with hydraulic equipment.

4.2 Before putting into operation clean the machine, especially connections and threaded unions, of any traces of oil, fuel or preservatives before carrying out maintenance/repair. Never use aggressive detergents. Use lint-free cleaning rags and pay attention that the components are meticulously clean during reassembling after repair.

4.3 During dismantling of machines it is necessary to collect the outrunning hydraulic liquids completely, so that they cannot reach the ground. They have to be disposed properly according to the instructions.

4.4 Always tighten any screwed and thread connections that have been loosened during maintenance and repair. Observe the stipulated torques.

4.7 Aggressive material (acid, lye, solvent, vapour) can damage the machine. It is necessary to clean the whole machine if it must be exceptionally operated under such conditions or gets into touch with these materials. Additionally, the machine must be checked as described under 3.6.

5 Safety Instructions for Hydraulic Hoses



- ***by no means the hose must be exposed to brake fluid*** as this fluid will destroy outer layer of hose
- do not expose the hose to any of the following aggressive fluids:
 - acid, lye or solvent
 - alcohol and fuel
 - battery and automatic transmission fluid
 - phosphate ester

Clean hose immediately with water and detergent when it was exposed to such fluids.

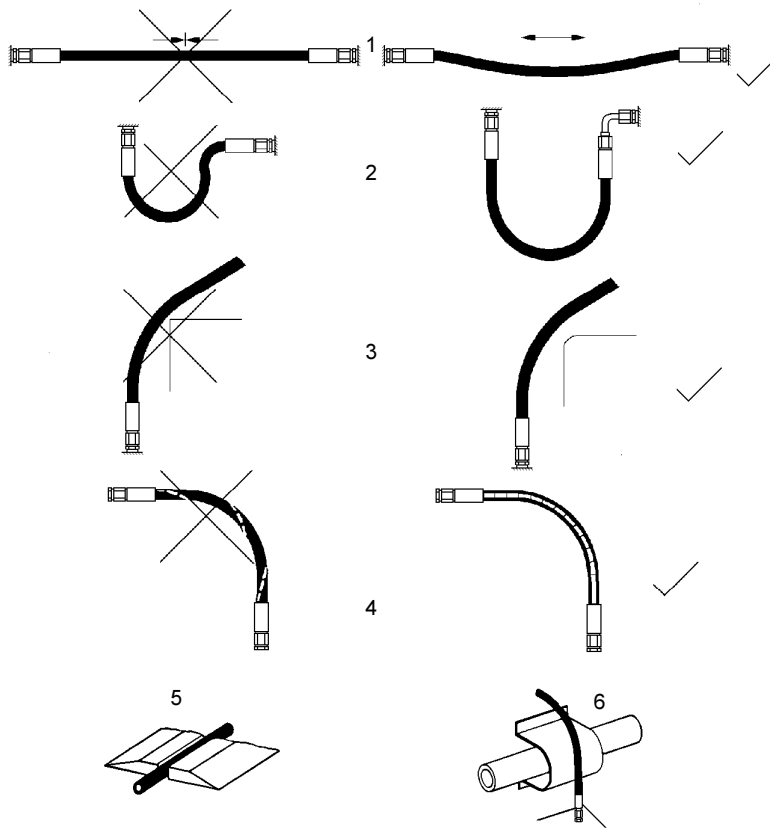

5.1 Handling of hoses

- never exceed the permissible working pressure as stated on hose and/or literature
- avoid any tension (see figure 1) and do not hang any load onto the hose
- never exceed the minimum bend radius as resulting kink will cause failure of hose (see figure 2)
- do not allow hose to contact sharp edges or rough objects (see figure 3)
- avoid any twisting of hose (see figure 4)
- do not run over hose with any vehicle or equipment ! Hoses which are put on the surface of sidewalk or street have to be suitably protected (see figure 5)
- do not allow hose to contact areas of high temperature such as mufflers, exhaust manifold, heaters or burners. Protect the hose as shown in figure 6 or install it in sufficient distance from the source of heat.
- never interline hose with that of a different manufacturer

5.2 Protection of the working area in case of breakdown of hoses

Hoses have to be installed or protected in such a way that dangers are prevented, if possible, in case of breakdown of the hoses.

Danger can be caused by:

- Uncontrolled hose movement after a hose rupture caused e.g. by external influence.
- Emerging of the pressure medium under pressure.

- Inflammation of pressure medium near igniting sources

Dangers can be prevented by e.g. protective coverings or shieldings

5.2.1 Do not go near leaks!

- High pressure oil easily punctures skin causing **serious injury**, gangrene or death!
- If injured, **seek emergency medical help!** Immediate surgery is required to remove oil!
- Do not use finger or skin to check for leaks!
- Lower load or relieve hydraulic pressure before loosening fittings!



5.3 Storage of hoses

Hoses are subject to a natural aging even if they are stored correctly. Therefore, their storage and service time is limited.

When storing the hoses please observe the following:

- Store them cool, dry and dustless (eventually wrapped with plastics sheeting); prevent direct solar radiation and UV rays; shield heat sources which are near the hoses.
- Do not use any ozone producing lamps (e.g. fluorescent light sources, mercury-vapor lamp) or electrical devices next to the hoses.
- Hoses have to be stored freely of tension and in a horizontal position. If they are stored in rings the smallest bending radius determined by the manufacturer must not fall below.

5.4 Marking of hoses

- The hose is marked with the manufacturer's name and quarter/year of production.
- The max. allowable pressure and month/year of production is indicated on the hose end fitting.

5.5 Inspection and replacement intervals of hoses

- **After each operation the hoses have to be checked for external damages, cracks, kinks and bubbles!**
- The operator has to replace the hoses in appropriate period of times, even if there are no visible security defects on the hoses.
- **The hoses have to be replaced 10 years as from date of manufacture at the latest (see marking on the hose)!**
Hoses are subject to a natural aging even if they are stored correctly. Therefore, their storage and service time is limited.
- **Hoses have to be checked by a skilled person before the first putting into operation of the technical device and afterwards at least once a year for their safe working condition.**

A skilled person is somebody having sufficient knowledge concerning hydraulic hoses due to his special training and knowledge. He/she must be acquainted with the local safety working conditions, accident prevention regulations, technical regulations and approved standards (e.g. DIN-Standards), so that he/she is capable to estimate the safety working conditions of the hydraulic hoses.

5.6 Examples for possible defects of hoses

- Damages of the surface and the interior (e.g. chafe marks, cuts or fissures).
- Embrittlement of the surface (fissuration of the hose material).
- Deformations, which are not in accordance with the natural shape of the hoses, in pressureless condition or under pressure or in case of bendings, e.g. separation of material layers, blister formation, squeezing or break spots.
- Leakage points.
- Instructions for installation were not observed.
- Emerging of the hose from the end fittings.
- Damages or deformations of the end fittings which deteriorate the function and stability of the end fittings or the connection between hose and end fitting.
- Corrosion of the end fittings or the metal inlets, which deteriorates the function and stability.
- Storage and operation periods were exceeded.

6 Intended use

LUKAS hose reels serve for storage of extension hose pairs between a LUKAS motor pump and a LUKAS rescue tool. By unwinding the hose pair(s) the radius of action can perfectly be adjusted to the requirements of each individual rescue situation. By winding the hoses up, unnecessary hose length can safely be kept out of the scene.

7 Description

7.1 Double hose reel

The double hose reel consists of two hose drums sitting on a base plate. Standard double hose reels are supplied with two hose pairs, each 20 m long and fitted with quick couplers for connection of a LUKAS rescue tool. With a removable crank handle (5) the hose drums can be turned into the desired direction. A hose break (6) on top of the hose reel prevents that the hoses are unintentionally unwound during transport. Through a central shaft with rotary seal pressure is supplied from the motor pump to the hose pairs.

7.2 Hydraulic hoses (pump side)

The double hose reel in its basic version is meant for permanent installation on a LUKAS motor pump with frame shape „R“. For connection to the valve block on the motor pump the central shaft of the hose reel is mounted with three hoses (2 x colour red, 1 x colour blue), each 0.7 m long with swiffel nut M 14 x 1.5.

7.3 Hydraulic hoses (tool side)

Standard hose reels are delivered with two hose pairs (colours red/blue and yellow/blue), each 20 m long. As an option, hose pairs with a length of 10 m, 15 m, 25 m or 30 m can also be supplied. All hose pairs will come with quick couplers on one end for connection of a LUKAS rescue tool.

8 Installation possibilities of the device

8.1 Permanently attached to the motor pump

The double hose reel is to be mounted on motor pumps with frame shape „R“ as follows:

- Mount the double hose reel on the „open“ side of the frame and fix it with the 2 screws by screwing them into the counterthread on the aluminium bar as shown on figure 1.
- Lock the nipple in port T of the valve block with the steel ball and the locking nut as shown in figure 2.
- Connect the blue (return) hose with port T1 of the valve block.
- Connect the two red (pressure) hoses with port A respectively port A1 of the valve block.

8.2 Stand - by version

8.2.1 Mounting of the conversion kit

For use of the double hose reel in stand - by version a separate conversion kit (ref. 84150/5876) is necessary. This kit consists of two triangle-shaped aluminium handles and three quick couplers. The kit is to be mounted as follows:

- Fix the two handles on each longitudinal side of the hose reel by means of screw and aluminium bar with counterthread (see figure 3).
- Mount the male quick coupler (type StNi61-D, colour gold) on the blue hose, and the two female quick couplers (type StMu61-0, colour black) on the two red hoses on the hose reel (see figure 4).
Tighten all couplers with a torque of 45 Nm.

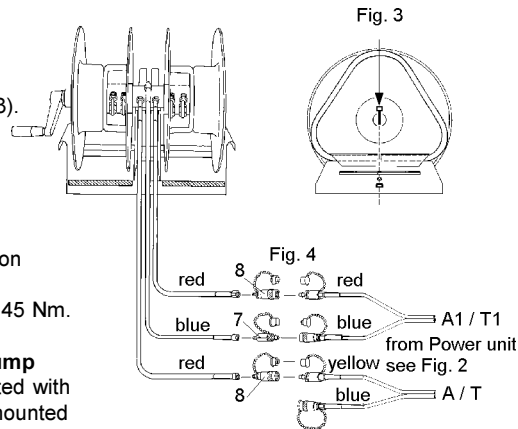

8.2.2 Connection with the motor pump

The stand-by hose reel must be connected with a LUKAS motor pump which is already mounted with two hose pairs (red/blue and yellow/blue): (see figure 4)

- Connect the blue hose of the red/blue hose pair with the short blue hose on the hose reel
- Connect the red hose of the red/blue hose pair with one short red hose on the hose reel
- Connect the yellow hose of the yellow/blue hose pair with the second red hose on the hose reel

Remark: the blue hose of the yellow/blue hose pair is not necessary in this configuration. It can stay unconnected.

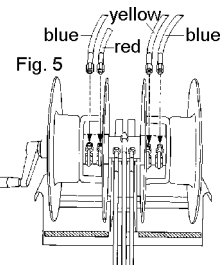

8.3 Special version without hoses

In special cases the double hose reel may be delivered without hose pairs for the tool side. In this case existing LUKAS hose pairs red/blue and yellow/blue are to be mounted as follows (see figure 5):

- Connect the yellow and the red hose with the inner elbow fittings on the shaft
- Connect the two blue hoses with the outer elbow fittings on the shaft

9 Hydraulic connection and set-up

9.1 Venting (only for first commissioning or after change of the hydraulic oil)

Prior to first commissioning the system must be vented: take the hose pairs on the hose drums and connect the yellow and the red hose with the corresponding blue hose to achieve an „internal“ oil circulation. Start the motor pump and let it run for a minute. Check the hydraulic oil level in the reservoir and refill hydraulic oil, if necessary.

9.2 Put the hose reel and the motor pump on even, firm and non-slip ground in sufficient safety distance from the site of operation.

9.3 Hydraulic connection

9.3.1 When connecting the hoses, be aware of the following basic function of the LUKAS quick couplers:

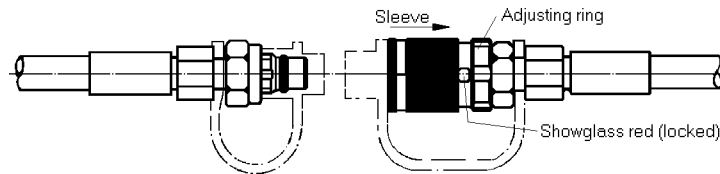

Before coupling, remove the dust protection covers and unlock the connect socket with adjusting ring by turning it. Withdraw the sleeve and connect plug and socket while holding the sleeve in this position. Release the sleeve and set the showglass to „red“ with the adjusting ring. Now the parts are connected and locked. Decoupling is done in the reverse order.

9.3.2 Connect one LUKAS rescue tool with the red/blue hose pair on the hose drum (red to red and blue to blue).

9.3.3 Connect the second LUKAS rescue tool with the yellow/blue hose pair on the hose drum. In this case it is permitted to connect the short red hose on the tool with the yellow hose of the hose pair.

9.4 Unwinding of hoses

Release the hose break by turning the knurled knob anticlockwise. Make sure that the hoses are running off smoothly.

Attention: do not stress the hoses by excess pulling ! See also safety regulations for hoses, page

9.5 Winding the hoses up

Lock the crank handle on one side of the hose reel shaft and turn the hose drum clockwise. When the hose pair is wound up, store the free end of the hoses in the latch between the two hose drums.

- Lock the hose break by turning the knurled knob clockwise.

9.6 Disconnection

For disconnecting the hose reel reverse the procedure as per 9.3 to 9.5

10 Maintenance and care

10.1 Hydraulic hoses must be replaced after 10 years as from the manufacturing date printed on the hose surface.

10.2 After each use:

- check the hoses, tubes and the seal on the rotary shaft on leakage. Check the fittings on the central shaft on
- leakage. Retighten them if necessary (tightening torque = 45 Nm)
check whether the quick couplers are clean and easily connectable

11 Repairs

Servicing must be carried out only by the device manufacturer or by personnel trained by the manufacturer or the authorised LUKAS dealers.

For replacement on all components, use only genuine LUKAS spare parts as specified in the spare parts list, as here possibly required special tools, mounting information, safety aspects, testing must absolutely be taken into account.

12 Problems/troubleshooting

Index: P = problem S = symptom

- P Quick couplers can not be coupled
S Adjusting ring on the socket is set to „red“ (= locked)
----> unlock the adjusting ring
- P Quick couplers on the pump side of the double hose reel can not be coupled
S Pressure in the hose(s) coming from the pump
----> release pressure by switching the valve on the motor pump to „zero“
- P Hoses can not be unwound
S The hose break is not released
----> open the knurled knob on the hose break
- P Oil leakage inside the hose drums
S Elbow fittings are not tightened properly
----> Tighten the fittings (tightening torque 45 Nm)
- P seal between hub and shaft is damaged
----> Contact for repair an authorised LUKAS dealer or the LUKAS service department.
The address:
LUKAS Hydraulik GmbH & Co. KG, Weinstraße 39, D-91058 Erlangen, Pf 2560, D-91013 Erlangen, service phone 09131/698 348; fax 09131/698 353

13 Technical data

13.1 LUKAS Hoses

Bending radius	Rmin = 38 mm
Burst resistance	safety factor: burst pressure/max. operating pressure min. 4 : 1
Temperature resistance	- 40°C ... +100°C
Operating medium	Mineral oil according to DIN 51524

13.2 Double Hose Reels

Type	DSH-20-2	DSH-20
Ref. No.	84150/5865	84150/5870
Hose length m	2 x 20	without hoses
Dimensions mm (l x w x h)	440 x 380 x 390	
Operating pressure MPa*	63	
Weight kg	42	20

* 1MPa = 10 bar;

13.3 Others

Working temperature	-20 +55°C
Ambient temperature (power pack in operation)	-24 +45°C
Storage temperature (power pack not in operation)	-30 +60°C

LUKAS Hydraulik GmbH & Co. KG
A Unit of IDEX Corporation
Weinstraße 39, D-91058 Erlangen
Postfach 2560, D-91013 Erlangen • Germany
Tel.: +49(0)9131/698-0 • Fax: +49(0)9131/698-394
e-mail: info@lukas.de

